



ME890PIB

UNIVERSAL SENSOR BRACKETS FOR ENCLOSURES

INSTALLATION AND OPERATION

1506 George Brown Dr.
 Marshall, MI 49068
 Phone (269) 789-6700
 Fax (269) 781-8340
www.marshallexcelsior.com

!WARNING!

Failure to follow these instructions or to properly install and maintain this equipment could result in an explosion and/or fire causing property damage and personal injury or death.

Install, operate and maintain Marshall Excelsior Co. equipment in accordance with federal, state, and local codes and these instructions. The installation in most states must also comply with NFPA standards 58 and 59, and ANSI K61.1

Only personnel trained in the proper procedures, codes, standards and regulations of the LP-Gas and NH₃ should install, maintain and service this equipment. Be sure all instructions are read and understood before installation, operation and maintenance. These instructions must be passed along to the end user of the product.

!CAUTION!

Contact or inhalation of liquid propane, ammonia and its vapors can cause serious injury or death. LP-gas and NH₃ must be released outdoors in air currents that will insure dispersion to prevent exposure to people and livestock. LP-Gas must be kept far enough from any open flame or other source of ignition to prevent fire or explosion! LP-Gas is heavier than air and will not disperse or evaporate rapidly if released in still air.

!CAUTION!

The power supply in an installed system may produce energy hazards, which can cause bodily harm. To reduce the risk of electrical shock, a trained service technician must disconnect the power supply cables from the battery terminals before installation or service of the system.

SCOPE OF THE MANUAL

This manual covers instructions for installation, wiring and use of the Marshall Excelsior (MEC™) ME890PIB Series Smart Interlock Technology bracket.

INTRODUCTION

The 890PIB series Interlock Brackets allow their users to verify that a door, lid or other enclosure is properly closed before shifting a transport out of park to move to another location. These products are designed to operate in a wide variety of temperatures, see Specifications.

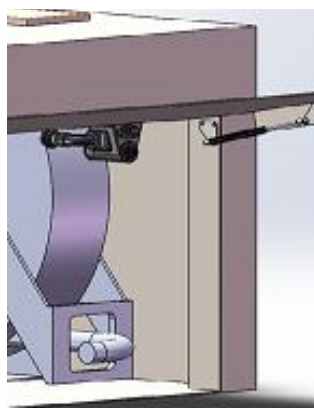
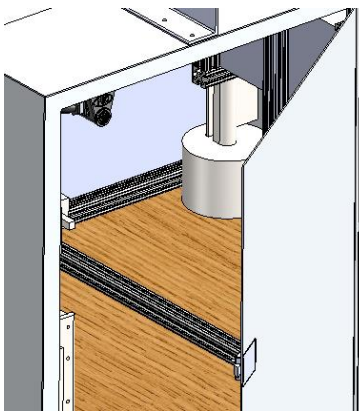

Specifications

	<i>Standard</i>	<i>Low Temperature</i>
Supply Voltage:	10-30 VDC	10-30 VDC
Max Current Draw:	200 MA (0.2A)	200 MA (0.2A)
Sensor Type:	Normally Open	Normally Open
Relay Type:	Normally Open	Normally Open
Fuse Rating:	1 AMP	1 AMP
Temperature Limits:	-20° to 160° F	-40° to 158° F

FEATURES

- Molded urethane sensor body housing for durability and maximum sensor protection
- Stainless steel mounting bracket and hardware
- Supplied standard with MEC Smart Interlock Technology
 - Technology features Turck® proximity switch for maximum weather resistance and security against vibration
 - Supplied with watertight conduit and necessary wiring hardware to reach 5' below deck with watertight receptacle plug
 - Optional wiring harness cable kits available in 20' or 30' lengths

	DESCRIPTION
ME890PIB	Universal Bracket Kit for enclosures
ME890PIBL	Low Temperature Universal Bracket Kit
CABLES AND KITS	
MEP801PC/20	20' Interlock Cable w / Watertight Receptacle Plug - Only
MEP801PC/30	30' Interlock Cable w / Watertight Receptacle Plug - Only
MEP801PCK/20	20' Interlock Cable: 1 Relay / LED Power Indicator / Inline Fuse
MEP801PCK/30	30' Interlock Cable: 1 Relay / LED Power Indicator / Inline Fuse
MEP802PCK/20	20' Interlock Cable: 2 Relay / LED Power Indicator / Inline Fuse
MEP802PCK/30	30' Interlock Cable: 2 Relay / LED Power Indicator / Inline Fuse
MEP803PCK/20	20' Interlock Cable: 3 Relay / LED Power Indicator / Inline Fuse
MEP803PCK/30	30' Interlock Cable: 3 Relay / LED Power Indicator / Inline Fuse

The contents of this publication are for informational purposes only. While every effort has been made to ensure accuracy, these contents are not to be construed as warranties or guarantees, expressed or implied, regarding the products or services described herein or for their use or applicability. Marshall Excelsior Co. reserves the right to modify or improve the designs or specifications of such products at any time without notice. The MEC™ logo is the trademark of Marshall Excelsior Co.



ME890PIB UNIVERSAL SENSOR BRACKETS FOR ENCLOSURES INSTALLATION AND OPERATION

1506 George Brown Dr.
Marshall, MI 49068
Phone (269) 789-6700
Fax (269) 781-8340
www.marshallexcelsior.com

INSTALLATION

NOTE: Before installing, inspect Interlock Assembly for shipping damage that may affect performance.

1. Install the Interlock Bracket into the enclosure or desired location as shown.

NOTE: The mounting holes are slotted for ease of adjustment after installation for sensor alignment. Maximum recommended bolt/screw size is 1/4".

NOTE: The ME890PIB Series does not use a flange cap to actuate the closing of a sensor circuit. The enclosure door or equipment that the sensor is being used on, must be closed or in the home position to close the circuit.

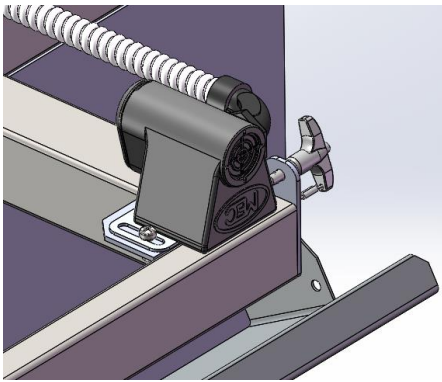

2. Adjust the position of the sensor so that the gap between the sensor's target reticle and the enclosure door or equipment is less than .062".
3. Route and Secure Conduit
 - a. Determine where the conduit is to be routed and where it will pass through the deck or cabinet wall:



- b. Secure conduit to support surface approximately every 6"-8" with suitable conduit clamp or wire tie (not provided).

4. Connect Interlock to Allison Transmission "Auxiliary Function Range Inhibitor"

!WARNING!

- The positive (+) supply conductor of the interlock circuit **MUST** be protected by a fuse with a maximum rating of 1 Amp, as provided in the MEC Proximity Cable Kits. It **MUST** be replaced only with a fuse of the same rating.
 - The maximum current draw through the sensor is 200 MA (0.2A)
 - Ground connections **MUST** be made as indicated by vehicle manufacturers' instructions
- a. Connect Sensor Cable plug to the mating connector on the 20' or 30' Single relay (MEP801PCK/20, MEP801PCK/30), Dual relay (MEP802PCK/20, MEP802PCK/30), or Universal (MEP802PC/20, MEP802PC/30) Proximity Cable Kit
 - b. Secure the connection in a protection location, route and secure all cables and wires using loom and wire ties or other suitable means.
 - c. Mount the sealed relay using the bracket provided, either in the engine compartment or cab as desired.
NOTE when mounting in the engine compartment, keep relay away from sources of heat and orient wires so they point downward.
 - d. Make the electrical connections as indicated on the Wiring Circuit Diagrams included in this manual. For final connections to the Allison "Auxiliary Function Range Inhibitor" circuit, follow the manufacturers' instructions provided with the Allison transmission.
NOTE: Only trained personnel that are qualified to make connections to the Allison Transmission's range inhibitor function, such as Allison Transmission certified technicians, should make these connections.
 - e. Test the Proximity Interlock / Range Inhibitor function for proper operation by setting the enclosure door or equipment to the home position, confirming that the red LED in the relay lights up indicating the circuit has been closed, and that the Range Inhibitor interlock function allows Allison Transmission to shift out of park. See Troubleshooting below

The contents of this publication are for informational purposes only. While every effort has been made to ensure accuracy, these contents are not to be construed as warranties or guarantees, expressed or implied, regarding the products or services described herein or for their use or applicability. Marshall Excelsior Co. reserves the right to modify or improve the designs or specifications of such products at any time without notice. The MEC™ logo is the trademark of Marshall Excelsior Co.



ME890PIB

UNIVERSAL SENSOR BRACKETS FOR ENCLOSURES

INSTALLATION AND OPERATION

1506 George Brown Dr.
 Marshall, MI 49068
 Phone (269) 789-6700
 Fax (269) 781-8340
www.marshallexcelsior.com

OPERATION

When the enclosure lid or equipment is closed or placed in the home position, the sensor is activated closing the sensor circuit. The circuit interfaces with the auxiliary function range inhibitor, allowing the vehicle transmission to be shifted out of Park position.

!WARNING!

Never operate with a leaking valve. Failure to follow these instructions could result in an explosion and/or fire causing property damage, personal injury or death.

MAINTENANCE

To ensure proper operation of MEC™ Smart Interlock Technology Brackets, perform the following maintenance at least once a month:

1. Check that all fasteners are secure. Tighten any that are found to be loose.
2. Check sensor relay for proper operation as indicated by red LED light on relay.

Trouble Shooting		
Problem	Possible Cause	Recommended Action
LED on relay does not light or relay does not activate	Relay not properly grounded	Mount the relay bracket to a grounded metallic surface or attach a ground strap between the relay bracket and an electrically grounded connection
	Protective over-current fuse is blown	Replace the fuse ONLY with a fuse of an identical 1 Amp rating
	No power to sensor	Remove cover on sensor housing to verify green light on Turck® sensor. If there is no light: <ul style="list-style-type: none"> Check fuse Check for 12 volts with key on Check ground wire from sensor
LED on relay does not light or relay does not activate	No signal from sensor	Remove cover on housing with enclosure door or equipment in the home position. Verify change light on Turck® sensor. If there is no light then sensor needs to be replaced.
	Wiring is Incorrect or Damaged	<ul style="list-style-type: none"> Check for 12 volts at Pin 1 of sensor plug with key on Check for 12 volts at Pin 2 with enclosure door/equipment in home position and key on Check for continuity between Pin 3 and negative (-) terminal of battery Check for any loose crimps or damaged wires Check for corrosion at all wiring connection points
	Faulty relay	Replace relay
LED on relay is lit but truck will not shift out of park	Wiring incorrect or damaged	<ul style="list-style-type: none"> Verify connections to and from the TCM of the transmission Check for any loose crimps or damaged wires Check for corrosion at all wiring connections
	Faulty relay	Replace relay
Connections test OK but interlock still does not function properly	Damaged or defective proximity sensor, sensor cable or sensor connector pins	Disconnect sensor connector and connect test jumper in its place. If interlock functions properly with test jumper but not with sensor, sensor must be repaired or replaced.

The contents of this publication are for informational purposes only. While every effort has been made to ensure accuracy, these contents are not to be construed as warranties or guarantees, expressed or implied, regarding the products or services described herein or for their use or applicability. Marshall Excelsior Co. reserves the right to modify or improve the designs or specifications of such products at any time without notice. The MEC™ logo is the trademark of Marshall Excelsior Co.

ME890PIB UNIVERSAL SENSOR BRACKETS FOR ENCLOSURES INSTALLATION AND OPERATION

ME890PIB WIRING DIAGRAM PROXIMITY INTERLOCK KIT

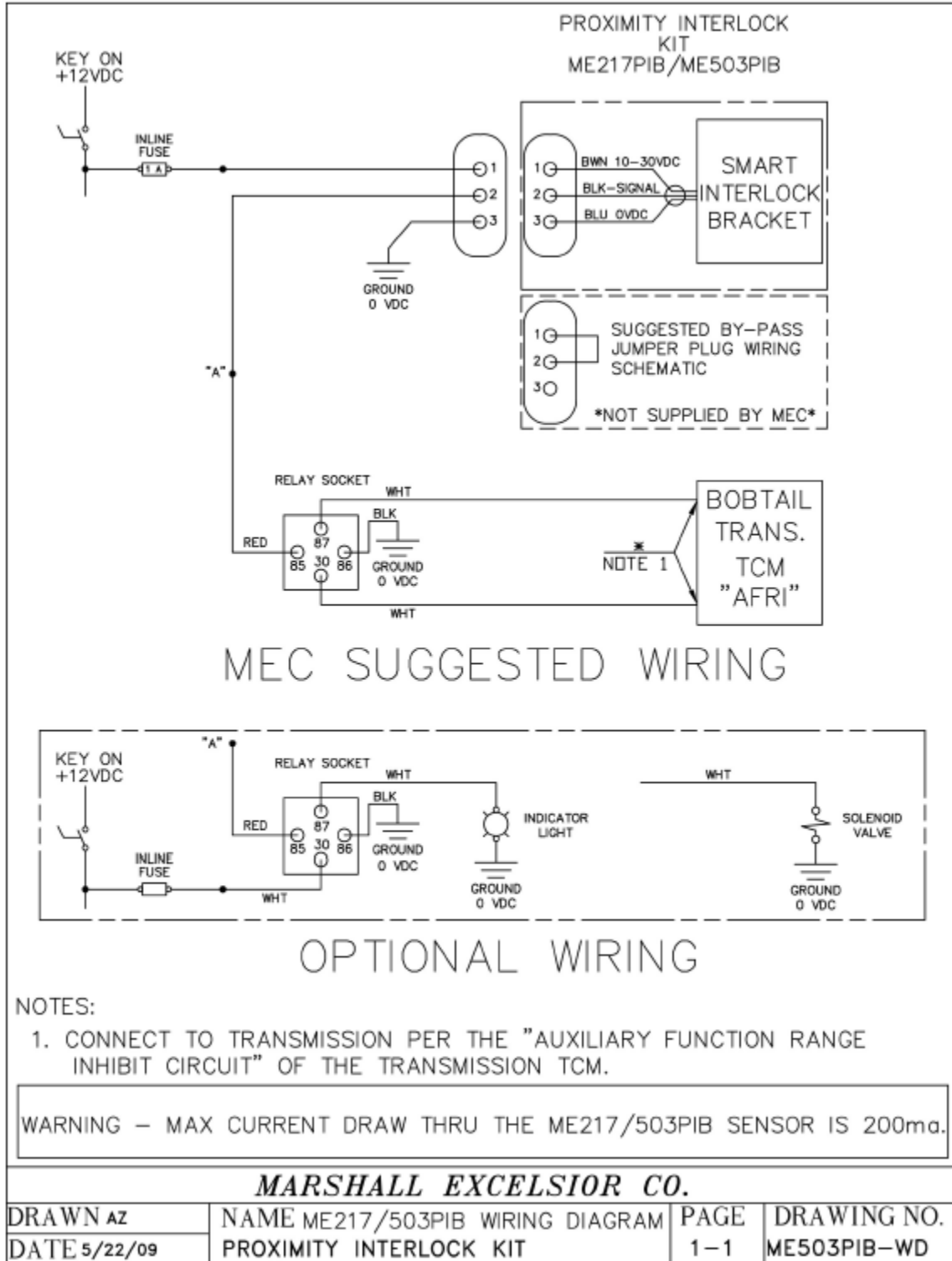

The contents of this publication are for informational purposes only. While every effort has been made to ensure accuracy, these contents are not to be construed as warranties or guarantees, expressed or implied, regarding the products or services described herein or for their use or applicability. Marshall Excelsior Co. reserves the right to modify or improve the designs or specifications of such products at any time without notice. The MEC™ logo is the trademark of Marshall Excelsior Co.

ME890PIB UNIVERSAL SENSOR BRACKETS FOR ENCLOSURES INSTALLATION AND OPERATION

ME801PC WIRING DIAGRAM PROXIMITY INTERLOCK KIT

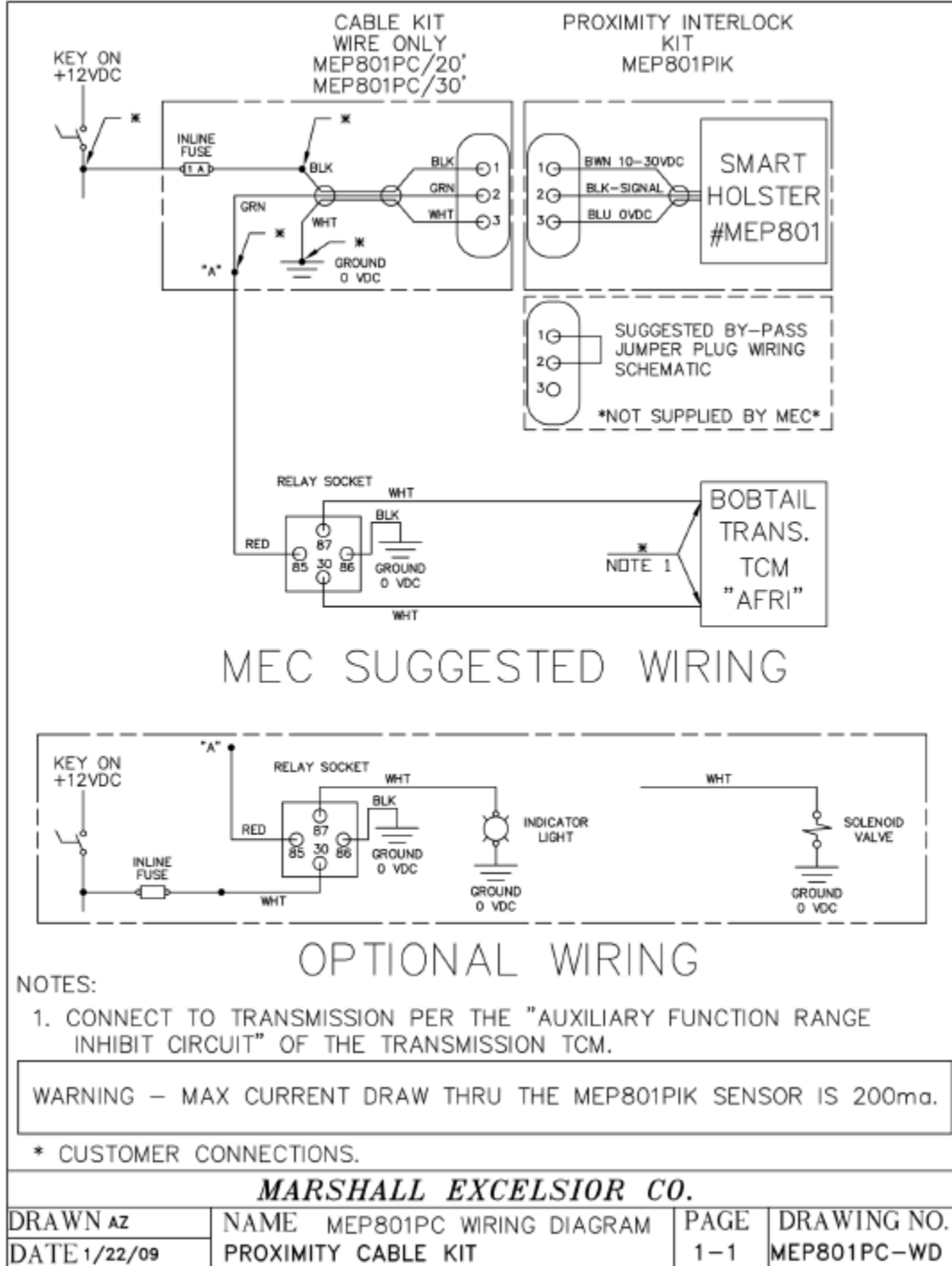

The contents of this publication are for informational purposes only. While every effort has been made to ensure accuracy, these contents are not to be construed as warranties or guarantees, expressed or implied, regarding the products or services described herein or for their use or applicability. Marshall Excelsior Co. reserves the right to modify or improve the designs or specifications of such products at any time without notice. The MEC™ logo is the trademark of Marshall Excelsior Co.



ME890PIB UNIVERSAL SENSOR BRACKETS FOR ENCLOSURES INSTALLATION AND OPERATION

1506 George Brown Dr.
Marshall, MI 49068
Phone (269) 789-6700
Fax (269) 781-8340
www.marshallexcelsior.com

ME801PCK WIRING DIAGRAM PROXIMITY INTERLOCK KIT

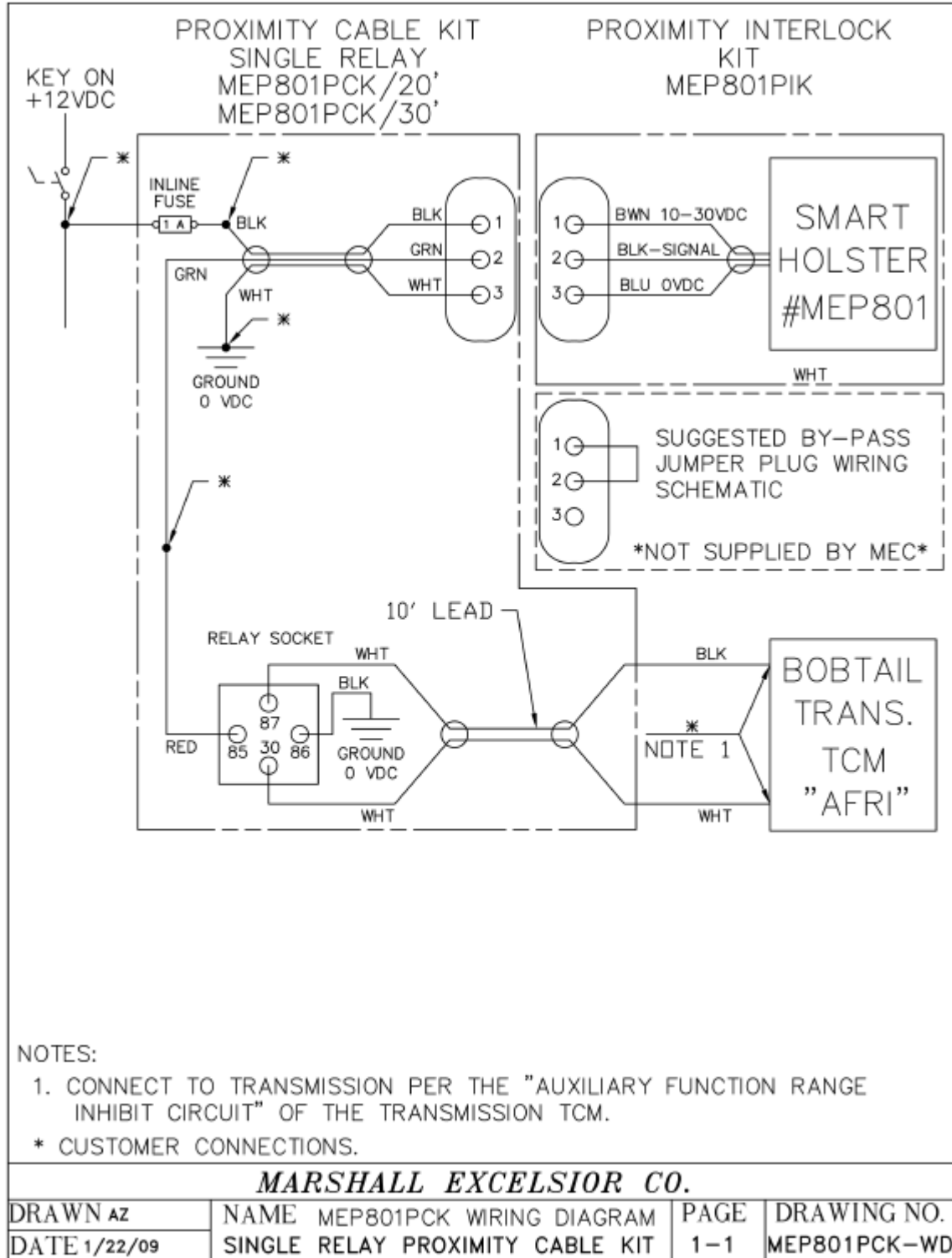

The contents of this publication are for informational purposes only. While every effort has been made to ensure accuracy, these contents are not to be construed as warranties or guarantees, expressed or implied, regarding the products or services described herein or for their use or applicability. Marshall Excelsior Co. reserves the right to modify or improve the designs or specifications of such products at any time without notice. The MEC™ logo is the trademark of Marshall Excelsior Co.



ME890PIB UNIVERSAL SENSOR BRACKETS FOR ENCLOSURES INSTALLATION AND OPERATION

1506 George Brown Dr.
Marshall, MI 49068
Phone (269) 789-6700
Fax (269) 781-8340
www.marshallexcelsior.com

ME802PCK WIRING DIAGRAM PROXIMITY INTERLOCK KIT

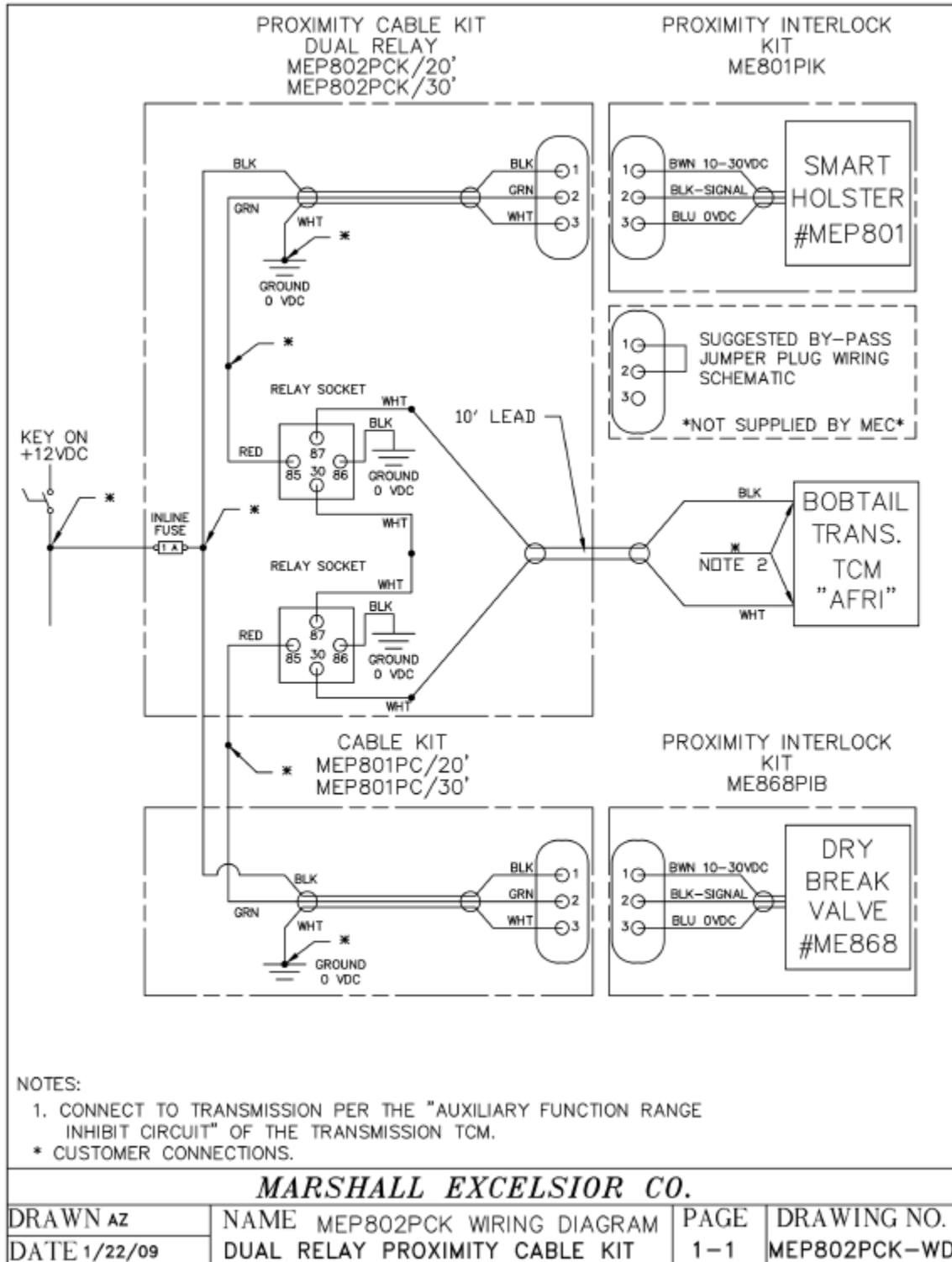

The contents of this publication are for informational purposes only. While every effort has been made to ensure accuracy, these contents are not to be construed as warranties or guarantees, expressed or implied, regarding the products or services described herein or for their use or applicability. Marshall Excelsior Co. reserves the right to modify or improve the designs or specifications of such products at any time without notice. The MEC™ logo is the trademark of Marshall Excelsior Co.