

Accu-Max+

Installation Information

1 Before you Begin & Qualified Installer Requirements

BEFORE YOU BEGIN

- **Carefully** read this Installation Guide before installing this product. If anything is unclear, please contact **BASE** Engineering for support.
- Ensure that the **NEGATIVE** battery connection is disconnected before beginning work.

NOTE: Some components may lose short-term memory (i.e. engine or transmission adaptive parameters and radio presets) after a prolonged time without battery power.



- Accu-Max+ should be serviced by qualified, trained personnel only. Attempting to remove the cover or disassemble the device could expose you to dangerous high voltage points.
- Do not attempt to install or operate a damaged device. If the unit has been exposed to excessive amounts of water, shows evidence of physical damage, or is not operating properly, unplug it from the power source and contact qualified service personnel.
- Use of thread-locking compounds, such as Loctite, may cause serious damage to plastic enclosures. Many thread-locking compounds are not compatible with thermoplastics and can lead to stress-cracking.

Marshall Excelsior Company

1506 George Brown Drive Marshall, MI 49068
Phone (269) 789-6700 Fax (269) 781-8340
www.marshallexcelsior.com

Base Engineering

600 Rothesay Ave, Saint John, NB E2H 2H1, Canada
Phone (506) 635-2280 Fax (506) 635-2281
www.baseng.com

The contents of this publication are for informational purposes only. While every effort has been made to ensure accuracy, these contents are not to be construed as warranties or guarantees, expressed or implied, regarding the products or services described herein or for their use or applicability. Marshall Excelsior Co. and BASE Engineering reserve the right to modify or improve the designs or specifications of such products at any time without notice. The MEC™/BASE™ logo is the trademark of Marshall Excelsior Co. and BASE Engineering.

QUALIFIED INSTALLER

This product is to be installed by qualified installation personnel only.

The installer must be trained in industry best-practices for this type of installation. The training would include but not be limited to:



1. The appropriate methods for installing cables such that:

- The operation of the vehicle is not interfered with.
- The installation process does not damage or interfere with other vehicle components and/or systems.
- Wiring is kept clear of sharp objects, sources of heat and any other hazard that could damage the cable or wire.
- Wiring is secured such that it does not cause damage to other equipment or itself, nor interfere with the operation of other systems and devices.
- Wiring through bulkheads is performed such that wiring does not chafe, and a seal is maintained between compartments.
- Appropriate, industry standard fasteners, splices, connectors and ties are used for the vehicle environment.
- Appropriate slack is in place to prevent straining of the wire, cable or connectors.
- Any other issue that could affect the integrity of the wiring or the safe operation of the vehicle is addressed appropriately.

2. The appropriate methods for mounting equipment in vehicles such that:

- The safe operation of the vehicle is not interfered with.
- The equipment is attached to the vehicle as securely as possible to minimize the risk of the equipment breaking free in an accident situation.
- The installed device does not interfere with the deployment of air bags.
- The installed device does not obscure displays or interfere with the ability of the driver to operate other vehicle systems and components.
- The installation process does not damage other vehicle systems or components.
- Compartments remain sealed against the elements.



3. The correct use and operation of the required tools such that:

- The installer must have the ability to read, understand and follow the instructions in the installation manual.
- The installer must be equipped with the correct tools for performing each installation operation.

The customer must ensure that the installation of all equipment provided for this project is safe, used for its intended purpose, and is in continual accordance with all applicable codes, rules, regulations and guidelines provided by motor vehicle and equipment manufacturers, as well as any state, local or jurisdictional bodies.

2 System Components

Accu-Max⁺ System includes the following key components:

1. Digital Dial
2. Barrier
3. Harness
4. Optional Brake Pressure Switch

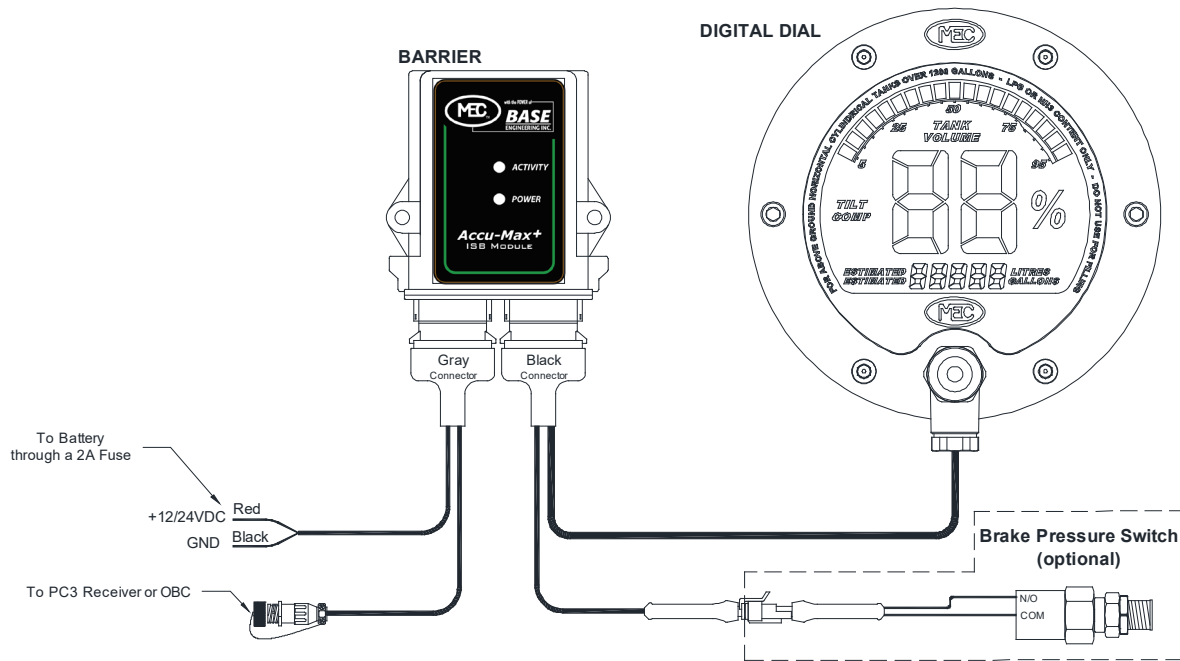

Figure 2-1 - Accu-Max⁺ System Drawing (Not to Scale)

3 Installation

- If the digital dial is used without activating the tilt compensation feature, it may be located in any of the 6 standard positions shown in Figure 2, including the default “End Mount” identified as Position 1.
- In order to enable the tilt compensation feature, the dial must be configured with the tank dimension parameters, float dimension parameters, as well as the Installation position.
 - The tilt compensation will only valid in the specified Position and cannot be relocated without reconfiguring the dial.
 - The estimated volume display will be automatically enabled when the tilt function is configured.
- The estimated volume field may be enabled without the tilt compensation if the float dimensions are not provided.

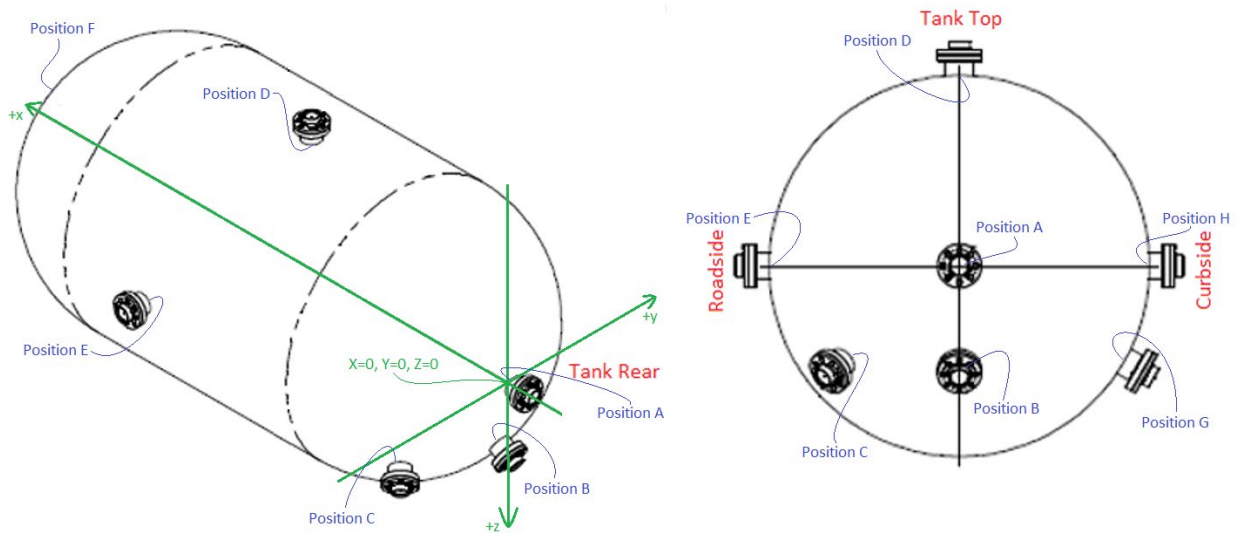
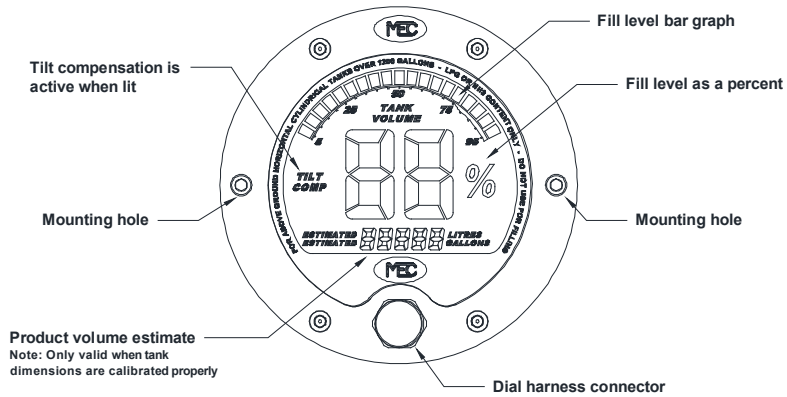

Figure 3-1 – Typical Installation Locations of Digital Dial

- Barrier is mounted inside the truck cab.
 - On transport trailers, the potted version of barrier may be installed exterior to the truck cab. In this case, ensure power is disconnected from the barrier while loading. This unit is not rated for hazardous locations.
- The cable with Black Deutsch connector is used to connect Barrier to Digital Dial and Break Pressure Switch (using the Break Pressure Switch is optional).
- The cable with Gray Deutsch connector is used to power up the Accu-Max+ system. To power up the system, locate the Red and Black wires and connect them directly to truck battery FUSED (2A fuse) and negative terminals. This cable also contains a separate RS485 communication port.

4 System operation

4.1 Digital Dial



4.2 BASE Engineering External Safety Barrier

The external safety barrier has 2 LED indicators and they are labeled as POWER and ACTIVITY.

- POWER LED is solid Blue when the system is ON, otherwise it is OFF.
- Activity LED:
 - If no remote host (e.g. BASE Receiver Module) is connected to Barrier, Activity LED is OFF.
 - If a remote host (e.g. BASE Receiver Module) is connected to Barrier (to communicate to a PC3 Receiver or an OBC, connect serial port to compatible RS485 port):
 - Activity LED blinks in Blue color when the system has normal communication between Digital Dial and PC3 Receiver or OBC.
 - Activity LED blinks in Red color indicates that the PC3 Receiver or OBC is communicating on the line, however the Dial may not have responded.



5 Operational Specification

- **Power Supply:** 12V / 24V (Absolute Range 9V – 32V)
- **Nighttime Backlit Current Draw:** 90mA @ 12V
- **External Fuse Rating:** 2A
- **Communication Link:** MODBUS over RS485 at 9600 Baud
- **Operating Temperature Range:** -40°C to +50°C
- **Fill Limits:** Selectable 5-95% or 3-97%

6 Mechanical Specification

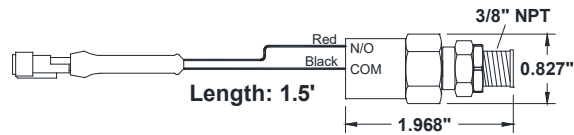
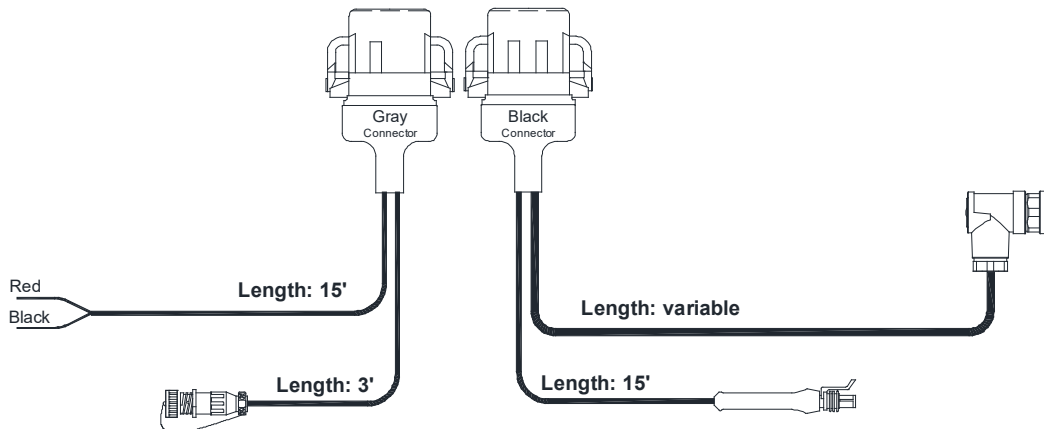
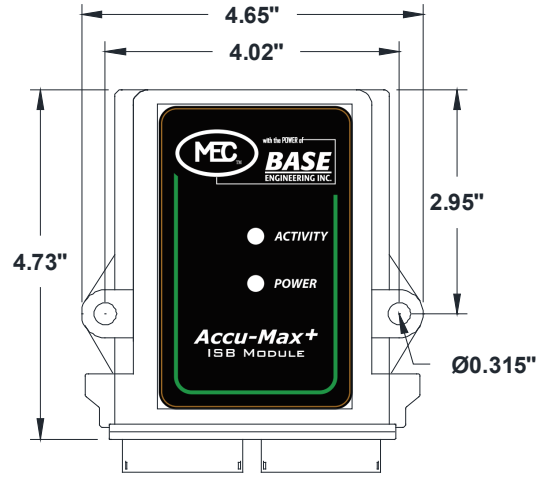
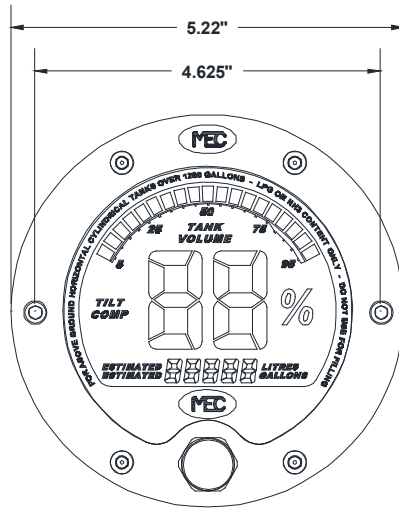



7 Dial Configuration

The basic “out-of-the-box” configuration of the Accu-Max+ digital dial can only provide a reading of the percentage fill of product within the tank. In order to enable the volume and tilt compensation, the dial must be loaded with all key details of the tank, including dimensions, float arm measurements and precise location of the dial.

Much of the required information is available on the Tank Plate (i.e. tank radius/diameter, length and shape), and several typical preset locations are available to aid in the configuration process. Additionally, the float arm dimension is required, along with any offset (into or out of the tank) in the mounting of the arm to be able to locate where the pivot point is of the arm within the tank (the key dimension needed in this case is any tank offset and the Flange-to-Pivot Length).

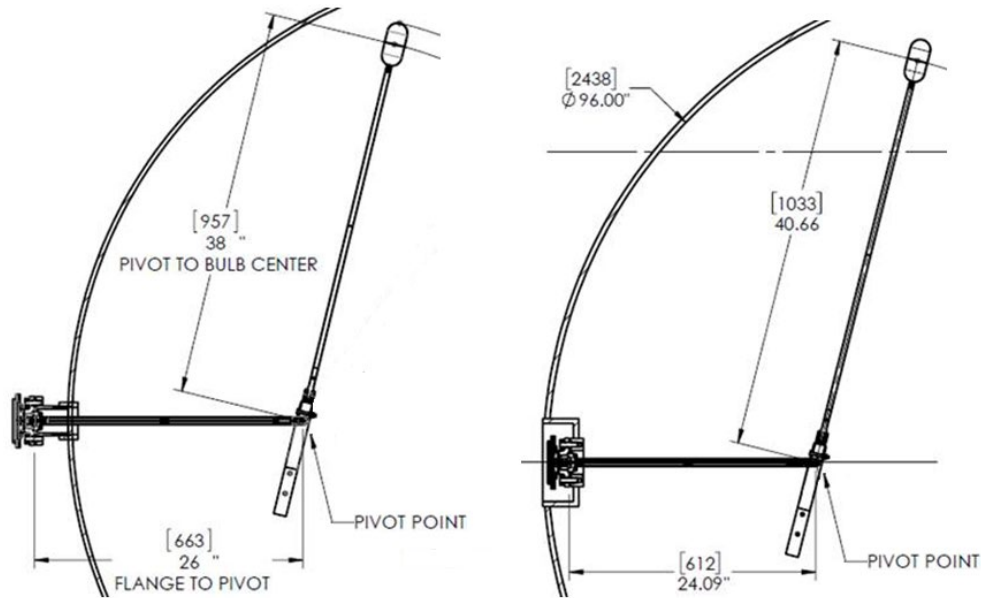

Figure 7-1: Float Arm Mounting - Pivot Point and Proud/Recess Mount

Use the table below to help gather all required information:

Table 7-1: Dial Configuration Worksheet

Parameter	Value	Notes
Tank Length, inches		Outer dimension. Generally stamped on the tank plate.
Tank Radius, inches		Outer dimension. Generally stamped on the tank plate.
Shell Thickness, inches		Generally stamped on the tank plate.
Tank Head Shape ("Hemisphere"/"Elliptic")		Generally stamped on the tank plate.
Mounting Point Proud/Recess, inches		See Figure 7-1.
Flange-to-Pivot Length, inches		See Figure 7-1.
Flange-to-Bulb Centre, inches		See Figure 7-1.
Mounting Position, A-G		As defined in Figure 3-1.
Volume Display Enable, Y/N		
Volume Units, Gallons/Litres		
Tilt Compensation Enabled, Y/N		
Backlight Color (Optional)		Select from: Green, Dark Blue, Sky Blue, Red, Yellow, Orange, Purple, Pink, Teal, Magenta, or White.
Tank Identifier (Recommended)		Serial Number or unique identifier of tank.

8 Troubleshooting

8.1 Barrier Troubleshooting

- **Blue Power LED is not illuminated.**
 - Ensure barrier has power, with a voltage range not exceeding +9V to +32V.
 - Check for blown 2A fuse and replace it if necessary.
 - Ensure vehicle is providing power to barrier (verify operating conditions of the vehicle (e.g. keyed power via ignition, physical disconnection of power connector on transport, etc.)
- **Activity LED is not illuminated.**
 - The Activity LED will only be illuminated if data is present on the RS485 bus.
 - If data is present on the bus and the LED is not illuminated, verify the RS485 data cable of PC3 receiver or OBC is secured to the barrier harness (on the Grey Deutsch Connector).
- **Activity LED intermittently switches from Blue to Red.**
 - This condition can occur during normal operation. Confirm that data is being received by the PC3 or OBC. If data is not being received, verify the connection between the Barrier and Digital Dial.
- **Activity LED blinks Red without any Blue.**
 - This condition indicates that the PC3 or OBC is sending data on the RS485 line, however the Digital Dial is not responding.
 - This may be a normal condition if multiple devices share the same data bus.
 - If the Digital Dial is not responding, and it should be:
 - Verify the connection between the barrier and dial.
 - Verify that the digital dial is powered on.
 - While the digital dial is on, it will display either the fill level or “- -”.

8.2 Digital Dial Troubleshooting

- **Display is blank**
 - Verify that power is being supplied to the Digital Dial.
 - Inspect the Barrier to ensure Power LED is solid Blue.
 - If the Barrier Power LED is Blue, verify the connection between the Barrier and Digital Dial.
- **Display is showing a double dash “- -”.**
 - This is a normal condition if the optional parking brake has been released or the dial has been commanded to turn off by optional PC3 or OBC.
 - Verify if the optional parking brake is engaged.
 - Verify via the optional PC3 or OBC if the display has been commanded “off”.

Appendix A: Hazardous Location Details

WARNING! When installed in hazardous locations where the dial may be exposed to flammable vapors (e.g. propane), the dial must be connected via a suitably rated intrinsically safe power supply. The connection of non-intrinsically safe power and communication could result in fire or explosion of flammable vapor causing serious injury or death.

Note: The insulation between the Intrinsically Safe Circuit and the body of the digital dial is below 500V rms.

Table A-1: Digital Dial UL Markings and Standards

UL Marking	UL/cUL Class I Zone 1 AEx ib IIB T4 Gb Ex ib IIB T4 Gb
Temperature Range	-40°C to +50°C
Applicable Standards	UL 60079-0, Seventh Edition UL 60079-11, Sixth Edition CAN/CSA C22.2 No. 60079-0, Third Edition CAN/CSA C22.2 No. 60079-11, Second Edition UL 508, Eighteenth Edition CSA C22.2 No 14-18, Thirteenth Edition

Entity Parameters:

Terminal M12 Connector Pins 4 and 5 to be connected to a simple apparatus.

Terminal M12 Connector Pins 1-3, 6-8

Parameter	Ui	Ii	Pi	Li	Ci
Group IIB	9.6V	610mA	0.94W	5.17uH	13.42uF

Environmental Ratings:

The relation between ambient temperature and the assigned temperature class is as follows:

Ambient temperature range	Temperature Class
-40°C ≤ Ta ≤ +50°C	T4

IP rating of 20.



Installation Notes:

1. Selected associated apparatus must be third party listed as providing intrinsically safe circuits for the application, and have Voc or Vt not exceeding Vmax (or Uo not exceeding Ui), Isc or It not exceeding Imax (or Io not exceeding Ii), and the Po of the associated apparatus must be less than or equal to the Pmax or Pi of the intrinsically safe equipment, as shown in Table A-2.
2. Capacitance and inductance of the field wiring from the intrinsically safe equipment to the associated apparatus shall be calculated and must be included in the system calculations as shown in Table A-2. Cable capacitance, Ccable, plus intrinsically safe equipment capacitance, Ci, must be less than the marked capacitance, Ca (or Co), shown on any associated apparatus used. The same applies for inductance (Lcable, Li and La or Lo, respectively). Where the cable capacitance and inductance per foot are not known, the following values shall be used: Ccable = 60 pF/ft., Lcable = 0.2 μH/ft.

TABLE A-2:

I.S. Equipment		Associated Apparatus
V max (or Ui)	≥	Voc or Vt (or Uo)
I max (or Ii)	≥	Isc or It (or Io)
P max (or Pi)	≥	Po
Ci + Ccable	≤	Ca (or Co)
Li + Lcable	≤	La (or Lo)

If Po of the associated apparatus is not known, it may be calculated using the formula $Po = (Voc * Isc)/4 = (Uo * Io)/4$.

3. Intrinsically safe circuits must be wired and separated in accordance with Article 504.20 of the National Electrical Code (ANSI/NFPA 70) or other local codes, as applicable.
4. In the United States wiring methods must be in accordance with the National Electrical Code, ANSI/NFPA 70, Article 504. Additional installation information can be found in ANSI/ISA-RP 12.6.
5. In Canada all wiring shall comply with the Canadian Electrical Code Part I and Local Electrical Codes