

Figure 1: example of in-line internal valve.

MEP889-X

MEP990-XDFM

!WARNING!

Failure to follow these instructions or to properly install and maintain this equipment could result in an explosion and/or fire causing property damage and personal injury or death.

Marshall Excelsior equipment must be installed, operated, and maintained in accordance with federal, state, and local codes and MEC instructions. The installation in most states must also comply with NFPA 58 or ANSI K61.1 standards.

Only personnel trained in the proper procedures, codes, standards, and regulations of the LP-Gas or anhydrous ammonia industries should install and service this equipment.

A. Introduction

Scope of the Manual

This manual provides installation instruction for the MEP889 series Threaded Bell Housings, and the MEP990-2DFM, -3DFM, -4DFM, -6DFM Flanged Bell Housing Kits.

Description

Marshall Excelsior Bell Housings are designed to be installed onto internal valves to allow in-line installations as shown in Figure 1. These Bell Housings are intended for use in LP-Gas or Anhydrous Ammonia (NH₃) service.

- MEP889 Series Bell Housings are designed for threaded internal valves and are available for 2" or 3" threaded piping connections.
- MEP990-XDFM Series Bell Housing Kits are designed for annular-groove flanged internal valves and are available for 2", 3", 4" or 6" 300# flanged piping connections.

B. Threaded Bell Housing Installation

1. Apply Loctite #565 or equivalent NPT thread sealant to threads of bell housing; install bell housing onto internal valve as shown in Figure 2.

Note: Ensure arrow on bell housing is pointing towards intended valve flow direction.

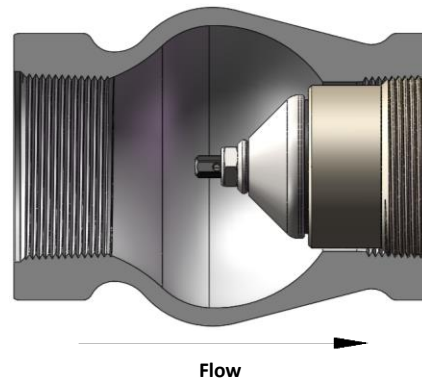

Figure 2: Threaded bell housing installed

2. Install opposite end of bell housing into piping connection.
3. Connect piping to a pressure source of at least 150 PSI. Check for leaks at both bell joints using a suitable leak detector solution such as "Marshall Excelsior" leak detector.

CAUTION: DO NOT USE THE VALVE IF ANY CONNECTION LEAKS UNDER PRESSURE

C. Flanged Bell Housing Installation

!CAUTION!

Spiral gaskets are not designed for repeated use; replace the gasket any time an annular-groove connection is broken and/or reassembled.

1. Place (1) spiral gasket onto inlet flange of internal valve. Install shorter thread-mount studs into bell housing as shown in Figure 3; install flange nuts onto studs and tighten in a star pattern to ensure even compression.

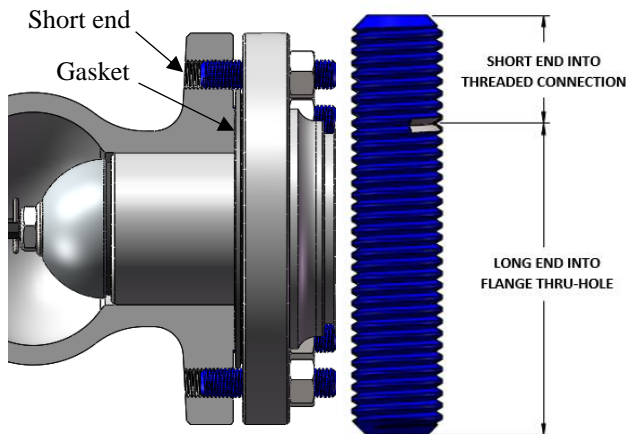

Figure 3: Thread-mount Stud installed

2. Install flange bushings into thru-holes of bell housing flange, see Figure 4.
3. Install longer thru-mount studs onto second flange of bell housing, with a flange nut on the end of each stud, see Figure 4
4. Install second spiral gasket against bell flange in between studs, then install Bell Housing into piping connection.
5. Install a flange nut onto each stud and tighten in a star pattern to ensure even compression.

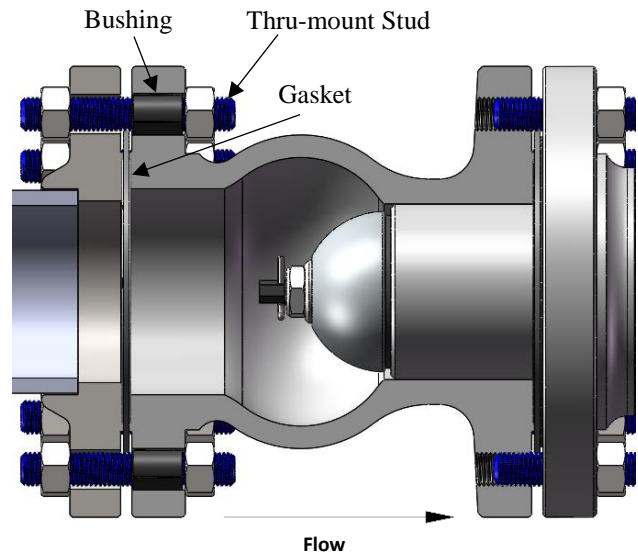

Figure 4: Final Installation

6. Connect piping to a pressure source of at least 150 PSI. Check for leaks at both bell joints using a suitable leak detector solution such as "Marshall Excelsior" leak detector.

CAUTION: DO NOT USE THE VALVE IF ANY CONNECTION LEAKS UNDER PRESSURE