



## ME983-SRK RAILCAR ESV SEAL REPAIR KIT

**!!!WARNING!!!**

READ AND UNDERSTAND ALL INSTRUCTIONS INCLUDED WITH THIS REPAIR KIT  
RELIEVE ALL PRESSURE FROM SYSTEM BEFORE REMOVING VALVE FOR SERVICE

**NOTE:** Numbers in brackets [ ] refer to the number in the valve component list.

### **!WARNING!**

Relieve all pressure from system before removing valve for service, and before any disassembly or repair.

Read and understand all instructions included with the repair kit, prior to starting any repairs.

### **!GENERAL WARNING!**

Marshall Excelsior products are mechanical devices that are subject to wear, contaminants, corrosion, and aging of components made of materials such as rubber and metal. Over time these devices will eventually become inoperative. The safe service life of these products will reflect the environment and conditions of use that they are subjected to. Regular inspection and maintenance is essential. Marshall Excelsior products have a long record of quality and service, so LP-Gas dealers may forget hazards that can arise from using aging devices that have outlived their safe service life.

#### **A. Disassembly of ME983 Railcar ESV**

1. Remove (8) Bonnet Screws [3] from Bonnet Adapter [2] and retain.
2. Remove Bonnet Adapter [2] from Body [1] and retain. Remove (3) Set Screws [4] from Bonnet Adapter and discard.
3. Remove Stem Bushing Retainer [5], Rulon Stem Bearing [6], and Bonnet O-Ring [7] from Bonnet Adapter [2]. Discard Rulon Stem Bearing, Bonnet O-Ring, and Set Screws. Retain Stem Bushing Retainer and Bonnet Adapter.
4. Remove Graphite Bonnet Seal [8] from Body [1] and discard.
5. Remove and retain Ex-Flow Spring Guide [9], Closing Spring [10] and Closing Spring Washer [11] from Stem Assembly [12].
6. Remove Stem Assembly [12] from Body [1].
7. Remove Lock Nut [12b], Bleed Disc [12c], and Valve Poppet Assembly [12d-12f] from Stem [12a]. Discard Bleed Disc.
8. Remove Excess Flow Spring or Spacer [12k] and Spring Seat [12m] from Stem [12a]. Retain Spring unless a new Excess Flow Spring was purchased. If so, discard the old spring.
9. Remove Stem O-Ring [12n] from Stem [12a] and discard.
10. Remove (6) Valve Poppet Screws [12h], (6) Lock Washers [12g], Seal Retainer [12f], and Main Valve Seal [12e] from Valve Poppet [12d]. Discard Main Valve Seal.
11. Remove Piston Retainer Assembly [13], Valve Piston Gasket [14], Piston Retainer O-Ring [15], and Piston Assembly [16] from Body [1]. Discard Piston Gasket and O-Ring.
12. Remove Shaft Seal Retainer [13b], Shaft Seal O-Ring [13c], Shaft Seal [13d], and Rulon Piston Bearing [13e] from Valve Piston Retainer [13a]. Discard Shaft Seal Retainer, Shaft Seal O-Ring, Shaft Seal, and Rulon Piston Bearing.
13. Remove Piston [16]; remove Wedge Set Screw [16d] and disassemble Piston. Discard Piston Seal [16b], and Wedge Screw [16d], retain Piston Top [16a] and Piston Base [16c].
14. Inspect Body [1] and Bonnet Adapter [2] and clean if necessary, be sure interior is free of dirt, residue, and foreign particles.

### **Marshall Excelsior Company**

1506 George Brown Drive Marshall, MI 49068  
Phone (269) 789-6700 Fax (269) 781-8340  
[www.marshallexcelsior.com](http://www.marshallexcelsior.com)

The contents of this publication are for informational purposes only. While every effort has been made to ensure accuracy, these contents are not to be construed as warranties or guarantees, expressed or implied, regarding the products or services described herein or for their use or applicability. Marshall Excelsior Co. reserves the right to modify or improve the designs or specifications of such products at any time without notice. The MEC™ logo is the trademark of Marshall Excelsior Co.

## ME983-SRK

### B. Reassembly

1. Apply Lubriplate or equivalent grease to Piston Seal [16b] and install onto Piston Top [16a] as shown below.
2. Apply Loctite #242 (Blue) or equivalent thread locker to threads of Piston Top [16a] and install into Piston Base [16c]. Install new Wedge Screw [16d] into Piston Assembly and tighten to retain.

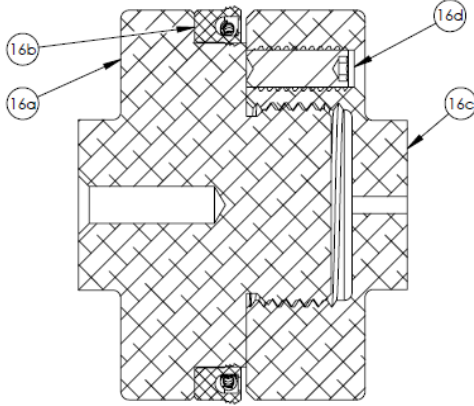

3. Install Piston Assembly [16] into Body [1] as shown using Installation Tool [17]. Discard Installation Tool after use.

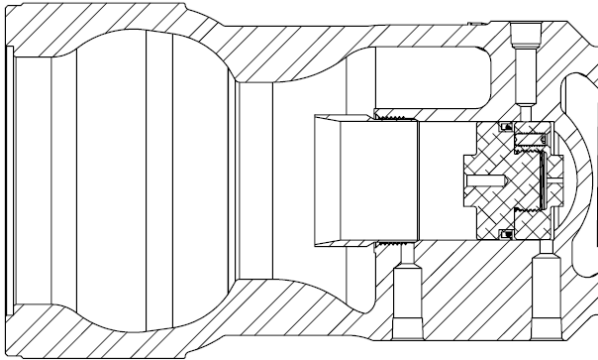

4. Install Rulon Piston Bearing [13e] into Piston Retainer [13a].
5. Apply Lubriplate or equivalent grease to Shaft Seal O-Ring [13c] and Shaft Seal [13d]; install seals into Valve Piston Retainer [13a] as shown.

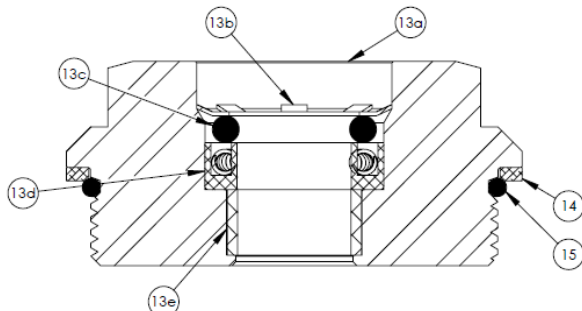

6. Install Shaft Seal Retainer [13b] into Piston Retainer until fully seated.

7. Install Valve Piston Gasket [14] and Outer O-Ring [15] onto Piston Retainer Assembly [13].
8. Apply Loctite #271 (Red) or equivalent thread locker to Piston Retainer Assembly [13] and install into Body [1].
9. Apply Loctite #271 (Red) or equivalent thread locker to Piston Retainer Assembly [13] and install into Body [1], tighten securely.
10. Install Main Valve Seal [12e] onto Valve Poppet [12d]. Install Seal Retainer [12f] onto Valve Seal.
11. Install (6) Lock Washers [12g] and (6) Valve Poppet Screws [12h] into Valve Poppet [12d], tighten in “star” pattern and confirm that all screws are torqued to 35 in-lbs.
12. Install Spring Seat [12m] onto Stem [12a] oriented as shown.
13. Apply Lubriplate or equivalent grease to Stem O-ring [12n] and install onto Stem [12a].
14. Install Excess Flow Spring [12k], Valve Poppet Assembly [12d-12h], and Bleed Disc [12c] onto Stem [12a].
15. Install Lock Nut [12b] onto Stem [12a] and tighten securely.
16. Install Stem Assembly [12] into Body [1].
17. Install Closing Spring Washer [11], Closing Spring [10], and Ex-Flow Spring Guide [9] onto Stem Assembly [12].
18. Install Graphite Bonnet Seal [8] into Body [1].
19. Apply Lubriplate or equivalent grease to Bonnet O-Ring [7] and install onto Bonnet Adapter [2].
20. Install Rulon Stem Bearing [6] and Stem Bushing Retainer [5] into Bonnet Adapter [2].
21. Apply Loctite #242 (Blue) or equivalent thread locker to (8) threaded holes of Body [1]. Install Bonnet Adapter [2] onto Body. Install (8) Bonnet Screws [3] through Bonnet Adapter into Body [1].
22. Install (3) Set Screws [4] into Bonnet Adapter [2] until cup end is flush with inside diameter of Bonnet Adapter.

After reassembly, connect the ESV outlet to a pressure source of at least 150 psi. Check for leaks at all assembly joints using a suitable leak detector solution such as “Marshall Excelsior” leak detector.

### **!CAUTION!**

**If any joint or seal continues to leak after reassembly, do not continue to use the valve.**

### C. Component List

<b>Item Number</b>	<b>Description</b>	<b>Qty</b>	<b>Included in Repair Kit</b>
1	Body	1	No
2	Bonnet Adapter	1	No
3	Bonnet Screw	8	No
4	Set Screw	3	Yes
5	Stem Bushing Retainer	1	No
6	Rulon Stem Bearing	1	Yes
7	Bonnet O-ring	1	Yes
8	Graphite Bonnet Seal	1	Yes
9	Ex-flow Spring Guide	1	No
10	Closing Spring	1	No
11	Closing Spring Washer	1	No
12	Stem Assembly		
12a	Stem	1	No
12b	Lock Nut	1	No
12c	Bleed Disc	1	Yes
12d	Valve Poppet	1	No
12e	Main Valve Seal	1	Yes
12f	Seal Retainer	1	No
12g	Lock Washer	6	No
12h	Valve Poppet Screw	6	No
12k	Excess Flow Spring or Spacer	1	No
12m	Spring Seat	1	No
12n	Stem O-ring	1	Yes
13	Piston Retainer Assembly		
13a	Valve Piston Retainer	1	No
13b	Shaft Seal Retainer	1	Yes
13c	Shaft Seal O-ring	1	Yes
13d	Shaft Seal	1	Yes
13e	Rulon Piston Bearing	1	Yes
14	Valve Piston Gasket	1	Yes
15	Piston Retainer O-ring	1	Yes
16	Piston Assembly		
16a	Piston Top	1	No
16b	Piston Seal	1	Yes
16c	Piston Base	1	No
16d	Wedge Set Screw	1	Yes
17	Installation Tool	1	Yes

ME983-SRK

