

#### WARNING!

Failure to follow these instructions or to properly install and maintain this equipment could result in an explosion and/or fire causing property damage and personal injury or death.

Marshall Excelsior equipment must be installed, operated, and maintained in accordance with federal, state, and local codes and MEC instructions. The installation in most states must also comply with NFPA 58 or ANSI K61.1 standards.

Only personnel trained in the proper procedures, codes, standards, and regulations of the LP-Gas or anhydrous ammonia industries should install and service this equipment.



**WARNING:** These products contain a chemical known to the state of California to cause cancer and birth defects or reproductive harm

#### Introduction

##### Scope of the Manual

This manual provides installation and maintenance instruction for the ME980-6, ME980C-6, ME980-8, and ME980C-8 Emergency Shutoff Valves and Cable Release or Pneumatic Release Assemblies.

##### Description

ME980 Series (Figure 1) emergency shutoff valves are intended for in-line use on LP-Gas or Anhydrous Ammonia (NH<sub>3</sub>) service.

The valves may be installed at both ends of transfer hoses where the hose connects the bulk plant piping to the bobtail, transport, or tank car. They provide a quick way of shutting off gas flow in the event of a hose rupture and meet the requirements for such

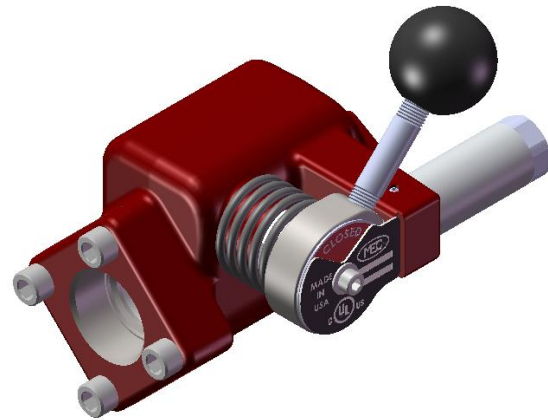

Figure 1 ME980-6 shown in closed position

service when correctly installed with a remote release and proper piping support. The ME980 Series ESV valves are lever operated, latch-open, and quick closing valves. A fusible element in the stem assembly melts if the temperature reaches 212°F (100°C), allowing the valve to close.

#### Operation

##### CAUTION!

The ME980 handle and shaft may break if the valve is forced open against the gas flow and before pressure is equalized on each side of the main valve disk.

##### To Open a Closed Valve:

Close a shutoff valve downstream of the ME980. Pull the ME980 handle to the "open" position. There will be a delay in opening as inlet pressure helps hold the valve disk closed against the seat. The initial opening force on the handle opens a pilot valve in the main valve disk, permitting pressure to build-up downstream. When differential pressure across the main disk has been reduced, the ME980 can be opened without further difficulty by continuing to pull the handle to the open position. When the handle is fully open the latch engages to hold the valve open.

### Marshall Excelsior Company

1506 George Brown Drive Marshall, MI 49068  
Phone (269) 789-6700 Fax (269) 781-8340  
www.marshallexcelsior.com

The contents of this publication are for informational purposes only. While every effort has been made to ensure accuracy, these contents are not to be construed as warranties or guarantees, expressed or implied, regarding the products or services described herein or for their use or applicability. Marshall Excelsior Co. reserves the right to modify or improve the designs or specifications of such products at any time without notice. The MEC™ logo is the trademark of Marshall Excelsior Co.

## ME980-6, ME980C-6, ME980-8, and ME980C-8

### CAUTION!

Because the valve is spring closed (aided by pressure), the handle can snap down with considerable force when closing. Keep hands and fingers away from the handle as it closes.

#### To Close an Open Valve:

Manually pushing the handle to the "closed" position will close the valve.

From a remote location, pulling on the remote cable release or exhausting pneumatic pressure from the ME980 latch will retract the latch plunger allowing the ME980 to close. If emergency conditions cause the fusible element to reach a temperature of 212°F (100°C), the fusible element, which attaches the handle to the shaft, melts and allows the valve to close automatically.

#### Installation

##### Shutoff Direction

The valves can be placed in a line used either for filling or withdrawing from the storage tank (or both). The valve shall be installed in the fixed piping between a storage tank and the transfer hose connection to shut off flow from the tank towards the hose.

### WARNING!

The ME980 valves are spring closed (aided by pressure) and shutoff flow in one direction only. THE NAMEPLATE FLOW ARROW SHOWS FLOW DIRECTION FOR VALVE SHUTOFF. The arrow shall point to the hose connection. Improper flow direction will not shutoff flow through the line.

The valve can be installed in vertical piping with the flow arrow pointing in the desired flow direction for valve shutoff. In some cases the normal flow through the valve may be opposite the shutoff direction (like a back check valve).

##### Fusible Element Location

A fusible element that will close the ME980 shall be located within five feet of the hose connection. If the ME980 is placed within five feet of the hose connection, this requirement is met. If not, an additional fusible element must be provided near the hose coupling which will activate a remote release.

#### Remote Release Installation

In all installations a remote release shall be connected to the latch on all emergency valves at the bulkhead. The remote release has to extend to a place where it can be easily reached to close the ME980 valve(s) in the event that an emergency makes the valve(s) inaccessible. The remote release shall shutdown all emergency valves when activated. Remote release activation may be by cable or pneumatic actuation.

### PNEUMATIC RELEASE CONNECTION

1. Attach the remote air source to the cylinder end with appropriate supply tubing and valving. A regulated air supply of **30 to 70 PSIG** to the ME980 pneumatic release cylinder is required for proper operation. **NOTE:** Nitrogen may be used as a pressure source.

### CAUTION

Possible hand and finger pinch points between closing ME980 handle and latch block. Handle closes quickly and with extreme force. Keep hands and fingers away from handle as it closes.

2. Test the remote release and ME980 operation. Open the valve. Valve must engage latch and stay open. **HANDLE AND VALVE MUST QUICKLY "SNAP" CLOSED** when (a) air pressure is exhausted from ME980 latch (b) remote cable release is pulled (if applicable), and (c) the handle is manually pushed closed from the open position.

### WARNING!

All open ME980 Emergency Valve(s) attached to the remote pneumatic release system must properly close when air pressure is exhausted from the system. Remote release controls must quickly exhaust pressure from the supply line to close emergency valves.

## ME980-6, ME980C-6, ME980-8, and ME980C-8

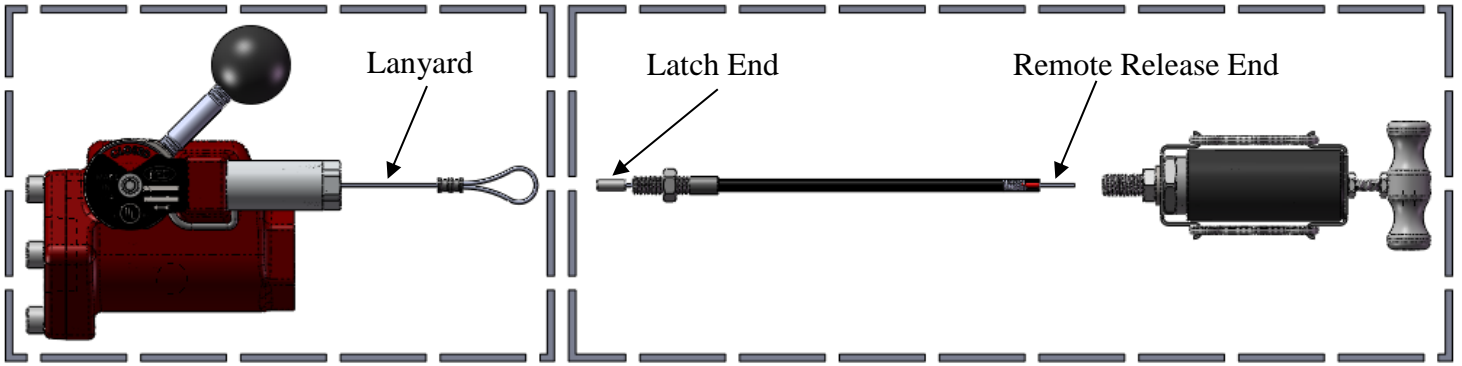
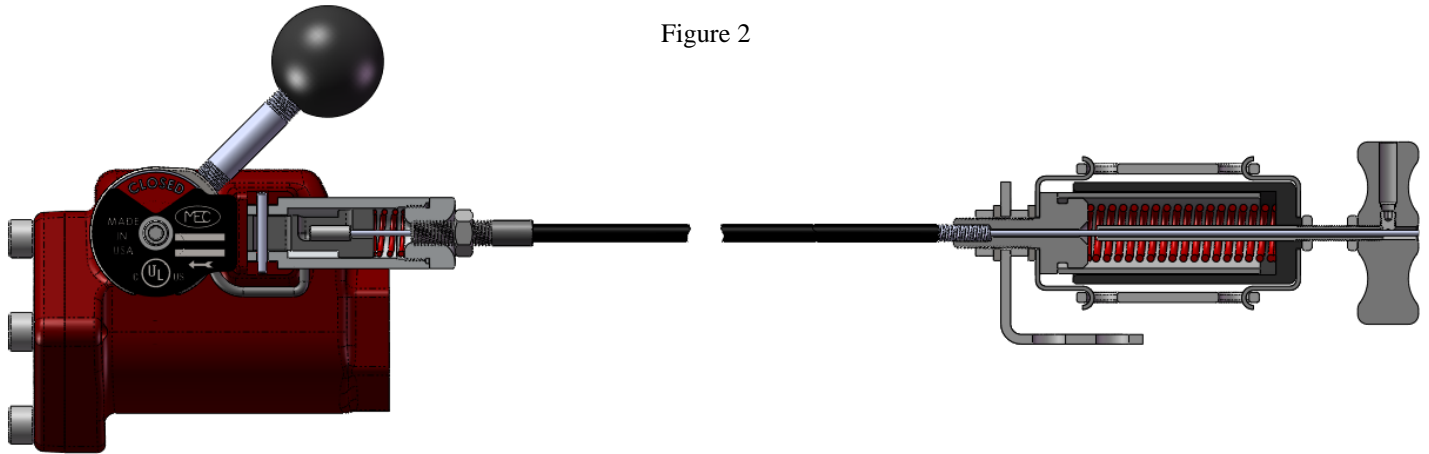

Figure 2



### CABLE RELEASE CONNECTIONS

#### WARNING!

Remote release cables shall be installed so that they will close the ME980 valve(s) when pulled from the farthest remote location. Cable shall operate smoothly, over pulleys and/or through conduit. Do not kink cable or run cable around sharp corners. If installed in conduit, keep water out of conduit. Frozen water, dirt or dried mud in the conduit will render the remote release inoperable.

Remote releases used on ME980 valves shall not:

- (a) be made from plastic or fiber rope;
- (b) have any kind of fusible link which could melt and prevent the cable from pulling the ME980 latch.

To provide a remote release, aircraft cable can be connected to the short looped cable on the valve and run to the remote release point over pulleys or through conduit. Adjust the cable so that minimal pull is required to close the emergency valves.

### ME980-906-25 or ME980-906-50

#### Cable Installation

To connect an ME980 remote release assembly, which is supplied with either 25' or 50' of cable:

1. Run the inner cable and housing assembly to the remote release point. Leave enough slack on each end for a smooth, flowing path, without sharp bends in the cable, between the ME980 latch and remote release handle.
2. If it is necessary to cut the cable to a shorter length, pull about one foot of inner cable from the ME980 latch cable end (end with the 3/16 by 1/2" long cylindrical cast fitting, (see Figure 2) from the housing).

At the remote release end (other end of inner cable housing assembly), cut the cable jacket and inner cable at desired length. Push the excess inner cable back through the housing so that the bare cable extends from the remote release end.

3. Close the ME980 valve.

## ME980-6, ME980C-6, ME980-8, and ME980C-8

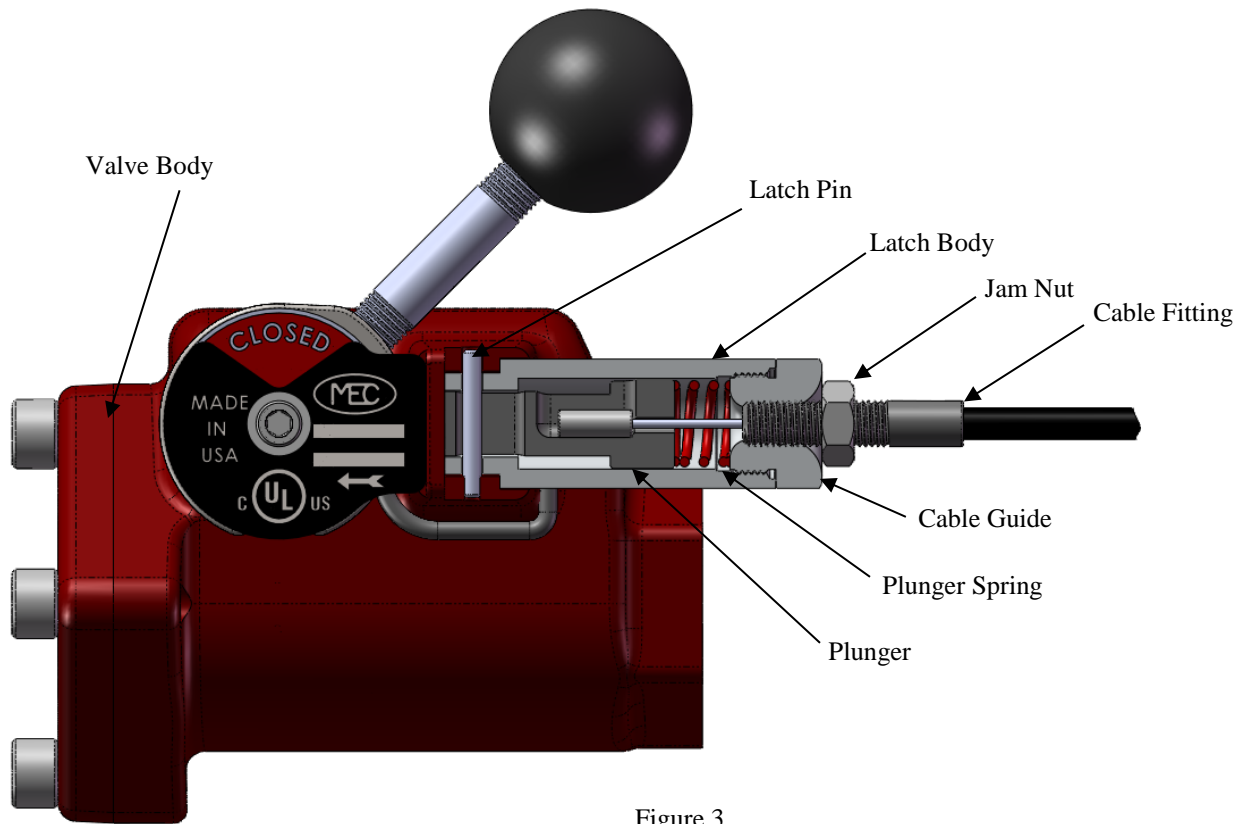
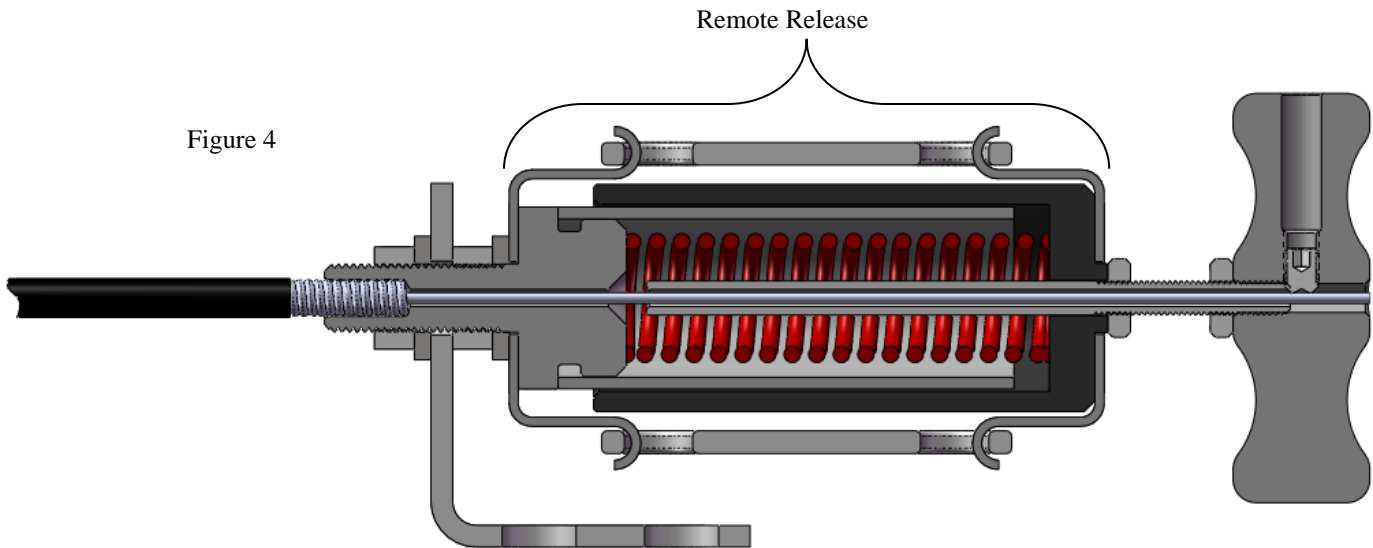

Figure 3

4. Unscrew the cable guide from the latch body.
5. Remove the latch pin from the valve body and remove the latch body from the valve body.
6. Remove the plunger, spring and lanyard (not shown).
7. Thread the cable guide onto the latch end cable fitting and tighten the jam nut.
8. Install the spring on the cable and insert the cable end in the plunger.
9. Install the plunger, spring and guide into latch body and **TIGHTEN SECURELY**.
10. Align the slot in the plunger, insert the latch body into the valve body and pin in place with latch pin.

## ME980-6, ME980C-6, ME980-8, and ME980C-8



11. Mount the remote release bracket to a suitable stationary support and mount the remote release to the bracket.
12. At the remote release end, strip 3/4" of vinyl cover from cable jacket.
13. Insert the inner cable end completely through the remote release with pull handle pushed all the way in. Release cable should extend beyond the pull handle.
14. Pull any slack through the remote release (with the pull handle pushed all the way in) and **TIGHTEN CABLE SET SCREW SECURELY.**
15. Test the remote release and ME980 operation from the most remote location. Rotate ME980 valve handle to open valve. Valve must stay open. **HANDLE AND VALVE MUST QUICKLY "SNAP" CLOSED** when (a) the remote release cable is pulled, and (b) ME980 valve handle is pushed closed from the open position.
16. Cut-off excess cable from pull handle.

### **WARNING!**

**All open ME980 emergency valve(s) attached to the remote release must properly close when the release cable is pulled.**

### **Maintenance**

#### **WARNING!**

**Only qualified service personnel should attempt to repair these valves. Before starting any type of repair, close off the upstream valves in the system and remove all pressure from both the inlet and outlet of the ME980 Emergency Shutoff Valve.**

At least once a month, inspect and check the following:

1. See that the remote release is properly connected, works freely, and is not worn. Operate the release to make certain it closes the valve. If the valve closes slowly, packing replacement may be required.
2. Make sure that the lever, latch, and release are working smoothly. The latch parts and lever are easily accessible for replacement or repair by removing the securing bolts.
3. Check for packing and joint leakage.

### **Replacing Internal Parts**

ME980 can be repaired in the field. However, due to the special fire resistant seals and assembly techniques, repairs should be done only by trained personnel. If repair should become necessary, contact your local Marshall Excelsior Distributor for information and assistance.

Only parts manufactured by Marshall Excelsior Co., should be used for the repair of ME980 Series ESV Valves. Be sure to give the complete model number of the ME980 valve when corresponding with your local distributor.

ME980 valves that have been disassembled for repair must be tested for proper operation before being returned to service.

## ME980-6, ME980C-6, ME980-8, and ME980C-8

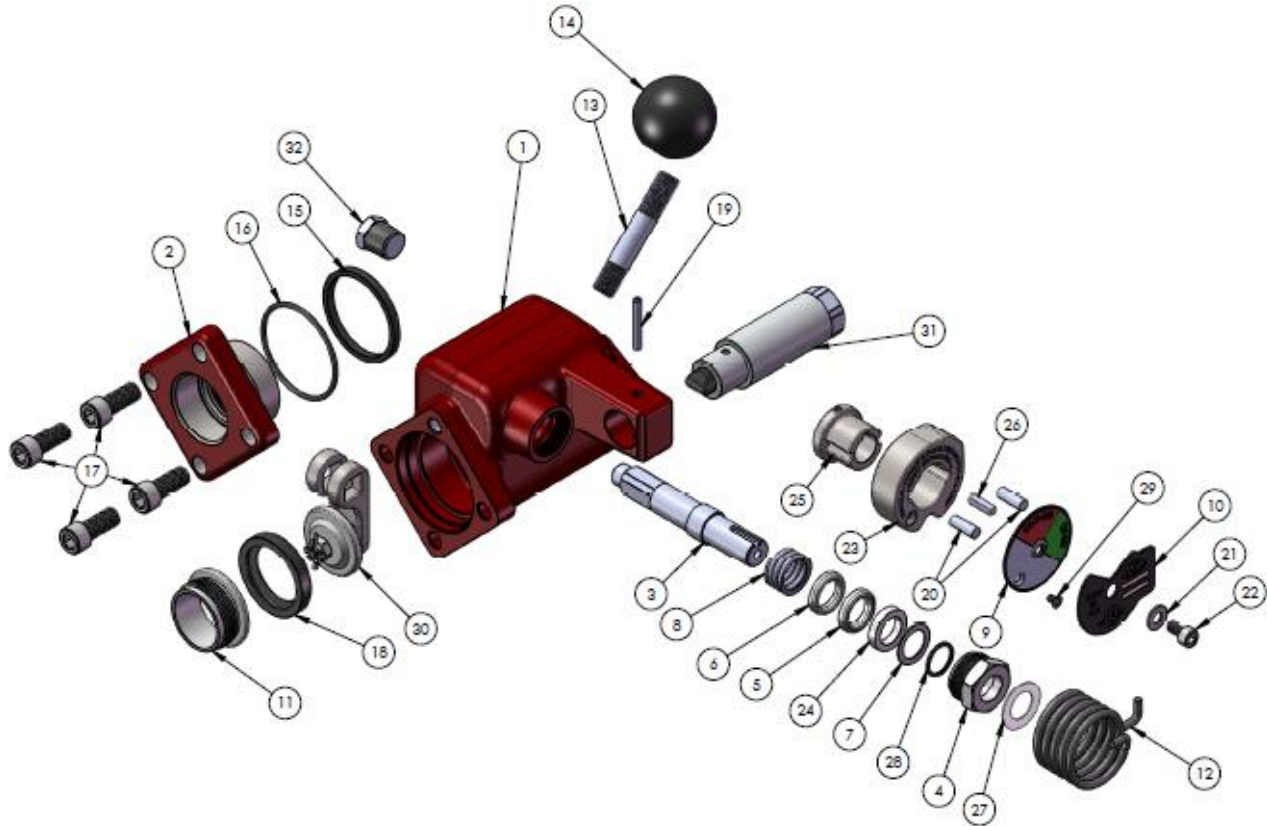

### Components List

- |     |                             |     |                                       |
|-----|-----------------------------|-----|---------------------------------------|
| 1.  | Body - 3/4" NPT or 1" NPT   | 21. | Handle Washer                         |
| 2.  | Flange - 3/4" NPT or 1" NPT | 22. | Handle Screw                          |
| 3.  | Stem                        | 23. | Handle Body                           |
| 4.  | Gland                       | 24. | Female v-Packing                      |
| 5.  | V-Packing                   | 25. | Spring Winder                         |
| 6.  | Male V-Packing              | 26. | Square Key Machined                   |
| 7.  | Packing Washer              | 27. | Stem Bearing Washer                   |
| 8.  | Packing Spring              | 28. | Gland Bearing                         |
| 9.  | Nameplate Dial              | 29. | Nameplate Screw                       |
| 10. | Nameplate                   | 30. | Clapper Assembly                      |
| 11. | Valve Seat Retainer         | 31. | Release Assembly - Cable or Pneumatic |
| 12. | Handle Spring               | 32. | 1/4" NPT Plug                         |
| 13. | Handle Rod                  |     |                                       |
| 14. | Handle Knob                 |     |                                       |
| 15. | Graphite Seal               |     |                                       |
| 16. | Flange O-Ring               |     |                                       |
| 17. | Flange Screw                |     |                                       |
| 18. | Valve Seat                  |     |                                       |
| 19. | Release Pin                 |     |                                       |
| 20. | Thermal Pin                 |     |                                       |