

**HIGH FLOW BY-PASS VALVE
INSTALLATION INSTRUCTIONS
FOR: ME840-16 AND ME840-125**

NOTICE

MEC bypass valves **must** only be installed in LPG & NH₃ systems that have been designed by qualified engineering personnel and operated and maintained by qualified technicians. The system **must** conform to all applicable local and national regulations and safety standards (specifically, LPG systems **must** conform to NFPA 58). This manual **must** be kept with the bypass valve and be reviewed **before** installation, putting into operation or performing any maintenance work.



WARNING: These products contain a chemical known to the state of California to cause cancer and birth defects or reproductive harm

!WARNING!

Do not attempt to open the pump or bypass valve until you have bled off the pressure. On systems with meters, the differential valve will keep liquid under pressure in the pump, meter and piping even when the hose is emptied.

INSTALLATION

On liquefied gas systems, a separate bypass valve, piped back to the supply tank, is necessary for maximum pump performance and longer pump life. The bypass valve must be installed in the correct position on the discharge side of the pump. (An arrow cast on the valve body indicates inlet and outlet.) The bypass valve will automatically prevent excessive pressure resulting from accidental pump overspeeding, discharge shut-off, or highly restrictive receiving systems. In general, size the bypass valve and its piping to accommodate the full flow from the pump when the pump's discharge line is closed and the pump is running at its rated maximum speed.

The bypass valve discharge must be piped back to the liquid or vapor section of the supply tank, never to the pump inlet. This method of piping should also be used when pumping volatile liquids from an underground tank or at high vacuum.

NOTICE

Bypass valve with welded connections

The bypass valve contains three O-ring seals that will be damaged if welding is done with these O-rings installed.

Prior to welding the piping, remove the O-rings from the inlet and outlet flanges and the bypass bonnet (Fig. 1). Reinstall the inlet and outlet flanges and weld the piping. Then reinstall the three O-rings.

OPERATION

Unless otherwise specified, the standard ME840 Flanged Series bypass valves are factory set at 125 psi (8.62 bar) differential pressure, with a maximum attainable pressure setting of 125 psi (8.62 bar) for LP-Gas and NH₃ service, per Underwriters Laboratories. For optional spring ranges and configurations, refer to the bypass valve parts list.

NOTICE

At temperatures below -20° F (-28.9° C) materials have reduced impact strength. Provisions should be made to prevent tools and other objects from impacting any pressure containing components of the pumping system.

Marshall Excelsior Company

1506 George Brown Drive Marshall, MI 49068
Phone (269) 789-6700 Fax (269) 781-8340
www.marshallexcelsior.com

The contents of this publication are for informational purposes only. While every effort has been made to ensure accuracy, these contents are not to be construed as warranties or guarantees, expressed or implied, regarding the products or services described herein or for their use or applicability. Marshall Excelsior Co. reserves the right to modify or improve the designs or specifications of such products at any time without notice. The MEC™ logo is the trademark of Marshall Excelsior Co.

**HIGH FLOW BY-PASS VALVE
INSTALLATION INSTRUCTIONS
FOR: ME840-16 AND ME840-125**

To check the pump's internal relief valve setting and the external bypass valve setting, follow these steps:

1. Install a pressure gauge equipped with a needle valve or snubber in the pump discharge gauge port. Install a pressure gauge on the tank and record the tank pressure.
2. Connect the delivery hose to the receiving tank.
3. Check all valves. The shut-off valve in the pump's discharge line, and the shut-off valve in the bypass return line should be open.
4. Start pumping at the normal rate. Make sure the supply tank outlet valve is fully open and check the direction of shaft rotation to be sure it matches the direction of the arrow on the pump.
5. Check the pressure setting of the pump's internal relief valve (when applicable) with the following procedure:

First, gradually close the shut-off valve in the bypass return line. Then slowly close the shut-off valve in the pump's discharge line while watching the gauge pressure on the discharge side of the pump. Record the peak differential pressure (the difference between the discharge and inlet pressure) when the internal relief valve begins to open.

NOTICE

It is important to read the peak pressure just before the pump relief valve opens. Once recirculation starts through the relief valve, vaporization will cause the pressure to fall quickly. For more information on the relief valve settings and adjustments, refer to the installation instructions for the specific pump.

6. After the relief valve setting has been determined, reopen the shut-off valve in the pump's discharge line and the shut-off valve in the bypass return line. Continue pumping at the normal rate.
7. To check the external bypass valve setting, gradually close the shutoff valve in the pump's discharge line and record the gauge pressure. The difference between this

reading and the tank pressure (before pumping) is the external bypass valve setting. The external bypass valve must be set at least 25 psi (1.72 bar) less than the pump's internal relief valve setting. This pressure setting will ensure that the liquid does not recirculate through the relief valve, and thus cause excessive pump wear and noise.

8. Reopen the shut-off valve in the pump's discharge line and resume normal pumping operation. Record the discharge gauge pressure. The difference between this reading and the tank pressure (before pumping) is the normal system operating pressure. The external bypass valve setting should also be at least 15 psi (1.03 bar) higher than the normal system operating pressure. (Operating pressures nearing the bypass valve setting may mean liquid is being recirculated unnecessarily.)

If necessary, adjustment to the external bypass valve can be made by removing the valve cap and loosening the locknut.

!WARNING!

Do not remove the valve cap on the bypass valve until you have bled off the pressure.

To increase the pressure setting, turn the adjusting bolt inward, or clockwise. To reduce the pressure setting, turn the adjusting bolt outward, or counterclockwise. Once a satisfactory pressure adjustment has been made, tighten the locknut, and replace the valve cap and tighten.

!WARNING!

Do not adjust the valve beyond the range of the spring being used.

**HIGH FLOW BY-PASS VALVE
INSTALLATION INSTRUCTIONS
FOR: ME840-16 AND ME840-125**

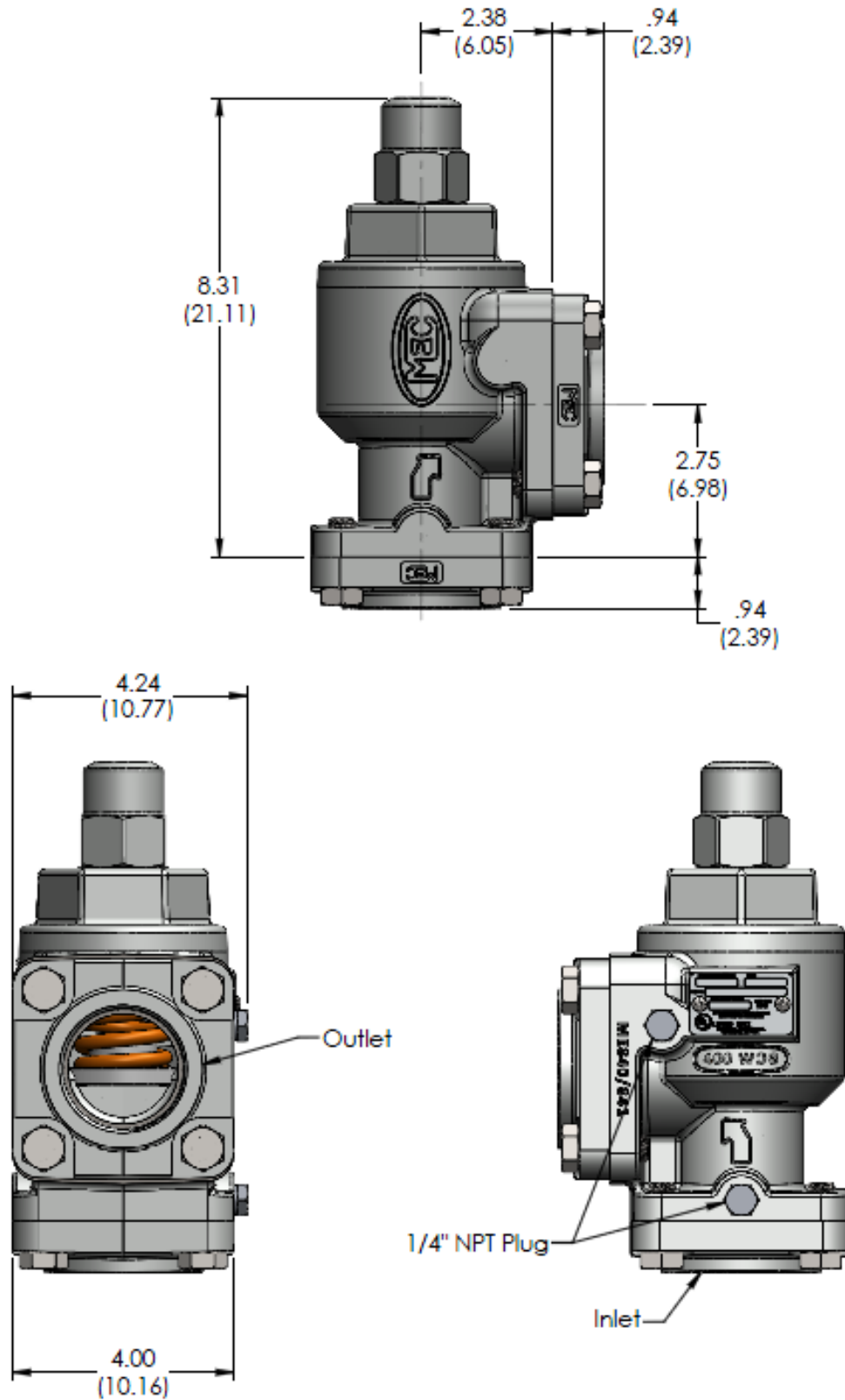

All dimensions are in inches (centimeters).

HIGH FLOW BY-PASS VALVE INSTALLATION INSTRUCTIONS FOR: ME840-16 AND ME840-125

Parts List				
Ref. #	Description	Qty	ME840K ME840VK	ME840SRK ME840VSRK
1	Body	1		
2	Poppet	1	✓	
3	Spring, Blue ¹	1		
	Spring, Green ¹	1		
	Spring, Yellow ¹	1		
	Spring, Orange	1		
	Spring, Red ¹	1		
4	Bonnet O-Ring, Nitrile or Viton ¹	1	✓	✓
5	Bonnet	1		
6	Spring Guide	1	✓	
7	Spring Guide O-Ring, Nitrile or Viton ¹	1	✓	✓
8	Stem	1	✓	
9	Lock Nut	1	✓	
10	Cap	1	✓	
11	Flange O-Ring, Nitrile or Viton ¹	2	✓	✓
12	Flange, 2" NPT	2		
	Flange, 2" Socket	2		
	Flange, 1-1/2" NPT	2		
	Flange, 1-1/2" Socket	2		
	Flange, 1-1/4" NPT	2		
	Flange, 1-1/4" Socket	2		
13	Hex Screw	8	✓	
14	1/4 " NPT Plug	4		
15	Nameplate	1		
16	Nameplate Screw	2		

¹ Alternate springs and Viton seals not U.L. Listed

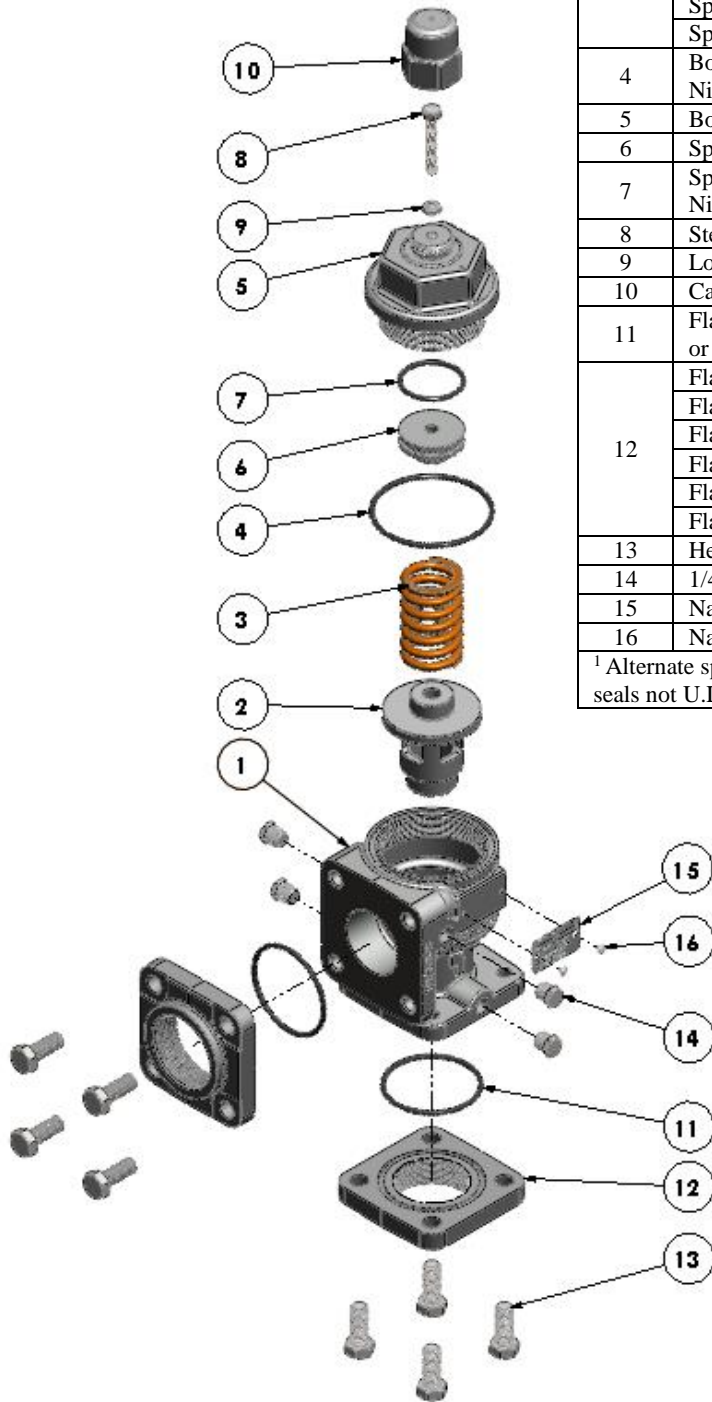

Figure 1