

!WARNING!

Failure to follow these instructions or to properly install and maintain this equipment could result in an explosion and/or fire causing property damage and personal injury or death.

Install, operate and maintain Marshall Excelsior Co. equipment in accordance with federal, state, and local codes and these instructions. The installation in most states must also comply with NFPA #58, ANSI K61.1 and DOT standards.

Proper installation of remote actuation devices should include thermal protection to close the internal valve in case of a fire. This pneumatic actuator includes thermal protection.

Only personnel trained in the proper procedures, codes, standards, and regulations of the LP Gas or anhydrous ammonia (NH₃) industries should install and service this equipment.



WARNING: These products contain a chemical known to the state of California to cause cancer and birth defects or reproductive harm

Introduction

Scope of the Manual

This manual covers instructions for the ME208SF Pneumatic Actuator kit. This kit allows for remote operation of the ME990-4F (Fisher® C404-32 and C484-32) internal valve.

Description

The Marshall Excelsior Co. ME208SF Pneumatic Actuator kit fits the ME990-4F (Fisher® C404-32 and C484-32) 4" flanged internal valve to allow for remote valve operation utilizing air pressure. Applying air pressure to the cylinder moves the cylinder rod and the internal valve's operating lever to open the valve. Upon loss of air pressure, the valve's operating lever immediately returns to the closed position.

This kit features a spring return design that eliminates the need for an air return.

Specifications

Pressure Source:	Air
Cylinder Pressure Limits:	Minimum – 20 psig Maximum – 125 psig Recommended – 20-25 psig
Temperature Limits:	-60°F to 250°F
Return Mechanism:	Spring only – no air



Installation

!CAUTION!

Do not manually stroke the cylinder.

The use of a pressure reducing regulator to supply the minimum cylinder operating pressure (20-25 psig) to the actuator will maximize cylinder and valve life and minimize air consumption.

1. To install an actuator kit, first remove any existing operating lever from the internal valve shaft.

!WARNING!

2. **For Fisher valves only:** When installing the ME208SF actuator onto a Fisher® C404-32 or C484-32, release all downstream pressure before removing the four bolts [4] holding the packing retainer plate to the internal valve body. Failure to follow these instructions or to properly install and maintain this equipment could result in an explosion and/or fire causing property damage and personal injury or death.
3. Assemble the Shaft Spline [2] and Shaft Spline Spring Pin [3] onto the internal Valve Shaft as shown below. **For Fisher valves only:** Remove the four bolts from the internal valve shaft area. Leave the packing retainer plate in place and discard the bolts.

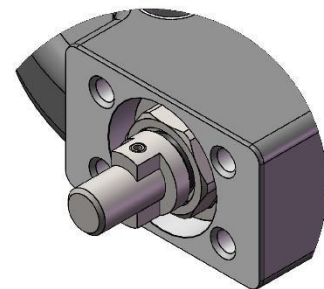

Marshall Excelsior Company
1506 George Brown Drive Marshall, MI 49068
Phone (269) 789-6700 Fax (269) 781-8340
www.marshallexcelsior.com

The contents of this publication are for informational purposes only. While every effort has been made to ensure accuracy, these contents are not to be construed as warranties or guarantees, expressed or implied, regarding the products or services described herein or for their use or applicability. Marshall Excelsior Co. reserves the right to modify or improve the designs or specifications of such products at any time without notice. The MEC™ logo is the trademark of Marshall Excelsior Co.

ME208SF

4. Pre-position the Linkage [5] in the hole of the Bracket [1] and simultaneously position both parts onto the internal valve shaft. Confirm the Linkage [5] mates with the Shaft Spline [2] already assembled on the internal valve shaft.
5. Install the (4) 3/8-16 x 1 1/4" Bolts [4] included with the ME208SF kit through the bracket (and internal valve packing retainer plate noted in the step 2 if installed on Fisher internal valve).
6. Remove the Cotter Pin [8] from the Clevis Pin [6] and Clevis Pin [6] from the Clevis [7]. Rotate the Linkage [5] forward on internal valve shaft.
7. **IMPORTANT** - To assure optimum flow and to prevent damage to the internal valve Shaft Spring Pin [3] by over-traveling the hard stop, the actuator clevis **MUST** be positioned correctly on the actuator. Verify that it is adjusted to the dimension shown below. If adjustment is required, loosen the clevis jam nut [10] on the cylinder rod [11] and adjust the clevis [7] to the dimension shown below. Tighten the Jam Nut [10] securely against the clevis [7].

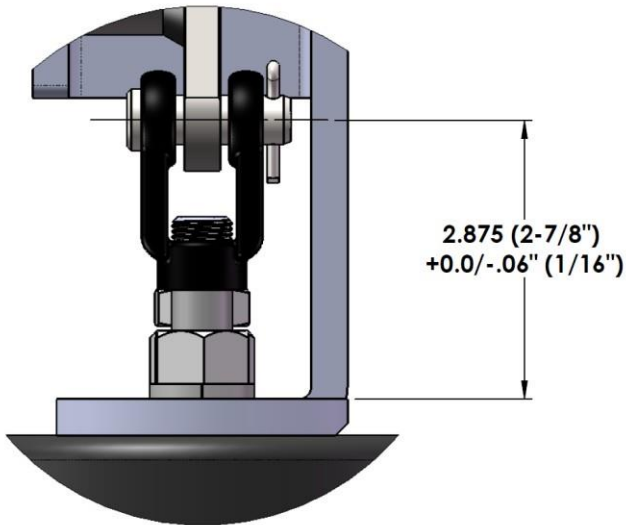

8. Position the Clevis Pin [6] through the Clevis [7] and Linkage [5]. Secure the Clevis Pin [6] with the Cotter Pin [8]. Install and tighten the Linkage Retainer [8], torque to 35 ft-lb [9] into the side of the bracket to retain the Linkage [5] in position on the shaft and Shaft Spline [2]. Install e-clip [13].
9. Connect the actuating pressure line tubing to the Swivel Connector [12]. After installing the actuator unit, operate the cylinder with pressure to verify it smoothly opens and completely closes the internal valve without sticking or jamming.

Maintenance

A simple preventive maintenance program for the valve and controls will eliminate many potential problems.

Marshall Excelsior Co. recommends these steps be conducted at least once a month:

1. Inspect the operating lever to see that it opens freely.
2. Confirm the actuator fully opens and closes the internal valve without sticking. Keep the actuator's drive coupling free of any build-up of mud, corrosion, or other

foreign material. Such a build-up could prevent the actuator from closing which could jam the internal valve in the open position. Do not permit this condition to occur.

3. Because the actuator has a diaphragm seal, internal lubrication is not required. For smooth operation, lubricate the linkage / clevis pivot point.
4. Inspect, clean, and oil all operating controls.

Component List

1. Bracket
2. Shaft Spline
3. Shaft Spline Spring Pin
4. Bolts, 3/8-16 x 1 1/4", Qty: 4
5. Linkage
6. Clevis Pin
7. Clevis
8. Cotter Pin
9. Linkage Retainer
10. Clevis Jam Nut
11. Cylinder Rod
12. Swivel Connector
13. E-Clip

