



MEGR-1232-DEMO DEMONSTRATION REGULATOR OPERATION INSTRUCTIONS

!WARNING!

This regulator is intended for demonstrational purposes only. Only operate regulator using compressed air. **DO NOT** use this regulator to contain harmful or dangerous gases such as LP-Gas or NH₃.



WARNING: These products contain a chemical known to the state of California to cause cancer and birth defects or reproductive harm

Introduction

The MEGR-1232-DEMO is a clear-plastic regulator designed to allow for observation of internal components during standard regulator function. This regulator is intended for informational purposes only and should be used for instruction on the standard function of regulators in the field.

Features

- Compact 2-Stage regulator function
- Clear plastic body
- Low pressure quick-connect inlet
- Ball valve on outlet for precise control of regulator during operation
- Side Port Pressure Tap
- Low-pressure Gauge attachment for use with Pressure Tap (not shown)
- Low-pressure Outlet Attachment for observing vent function

!CAUTION!

The MEGR-1232-DEMO is not a high pressure containing regulator. Do not exceed 120 psig during regulator operation.

Inlet Operation

Ensure ball valve is set to the closed position. Connect a low pressure air source to the quick-connect inlet, then apply pressure to the regulator.

The ball valve can be opened and closed freely during regulator operation to simulate demand and to observe function of the internal components.

Marshall Excelsior Company

1506 George Brown Drive Marshall, MI 49068
Phone (269) 789-6700 Fax (269) 781-8340
www.marshallexcelsior.com

The contents of this publication are for informational purposes only. While every effort has been made to ensure accuracy, these contents are not to be construed as warranties or guarantees, expressed or implied, regarding the products or services described herein or for their use or applicability. Marshall Excelsior Co. reserves the right to modify or improve the designs or specifications of such products at any time without notice. The MEC™ logo is the trademark of Marshall Excelsior Co.

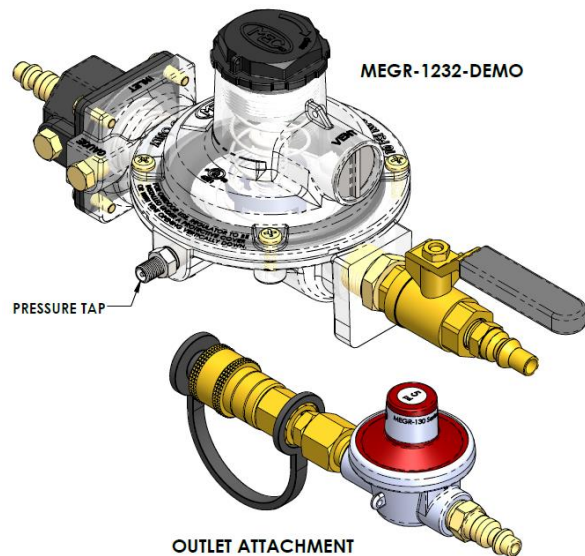

Pressure Tap Operation

Ensure ball valve is set to the Open position. Install Gauge Attachment (not shown) onto Pressure Tap. Connect a low pressure source to the quick-connect inlet, then apply pressure to the regulator. The gauge will show the current inches Water Column (W.C.) setting for the spring adjustor.

Deactivate pressure from the inlet and remove the cap from the regulator bonnet. Adjust the Spring Adjustor inside to either increase or decrease spring force. Replace the cap and activate inlet pressure, the gauge will show the change in W.C. setting.

Outlet Operation

Ensure there is no pressure connection on the Inlet side of the regulator. Install Outlet Attachment onto the Ball Valve, then connect the outlet to a low pressure source and apply pressure to the regulator.

The ball valve can be opened and closed freely during regulator operation to observe function of the vent.