



**ME779-VRK
QCC FILLER VALVE
VALVE REPAIR KIT**

!!!WARNING!!!

READ AND UNDERSTAND ALL INSTRUCTIONS INCLUDED WITH THIS REPAIR KIT
RELIEVE ALL PRESSURE FROM SYSTEM BEFORE REMOVING VALVE FOR SERVICE

NOTE: Numbers in brackets [] refer to the number in the valve component list.

!WARNING!

Relieve all pressure from system before removing valve for service, and before any disassembly or repair.

Read and understand all instructions included with the repair kit, prior to starting any repairs.

!GENERAL WARNING!

Marshall Excelsior products are mechanical devices that are subject to wear, contaminants, corrosion, and aging of components made of materials such as rubber and metal. Over time these devices will eventually become inoperative. The safe service life of these products will reflect the environment and conditions of use that they are subjected to. Regular inspection and maintenance is essential. Marshall Excelsior products have a long record of quality and service, so LP-Gas dealers may forget hazards that can arise from using aging devices that have outlived their safe service life.

A. Disassembly of ME777 Filler Valve

1. Remove Body Set Screw [3] and POL Tailpiece assembly [4-11] from Body [1] and discard.
2. Remove Handle [18], Handle Latch [17], Handle Latch Spring [20], and (2) Dowel Pins [21] and discard.
3. Remove Bonnet [17], Closing Spring [16], Closing Spring Retainer [15], Upper Stem Retainer [14], and Upper Stem [13] and discard.
4. Remove Stem assembly [12] from Body [1] and discard.

B. Reassembly

1. Apply Lubriplate or equivalent grease to Body Seal [2] and install into Body [1].
2. Install Collet Washer [5], Conical Bearing [7], and Light Spring [8] onto POL Tailpiece [4].
3. Install Collar [9] halfway onto POL Tailpiece [4].
4. Install Split Nuts #1 to #4 [6a-d] into Collar [9] in between Collet Washer [5] and Conical Bearing [7] as shown.
NOTE: Split Nut number is identified by a corresponding number of dots on the edge near the Acme thread.
5. Install Spring [10] and Spacer [11] onto POL Tailpiece [4].
6. Install POL Tailpiece [4] into Body [1] and torque to 50 ft-lbs.
7. Install Body Set Screw [3] into Body [1] and torque to 50 in-lbs.
8. Install Stem assembly [12] into Body [1] and torque Gland [12a] to 50 ft-lbs.
9. Install Upper Stem [13] and Upper Stem Retainer [14] onto Stem [12d]. Install Closing Spring Retainer [15], Closing Spring [16], and Bonnet [17] onto Upper Stem [13] and torque to 50 ft-lbs.
10. Install Handle [18], Handle Latch [19], Handle Latch Spring [20], and (2) Dowel Pin [21] onto Upper Stem [13].

After reassembly, connect the Filler Valve inlet to a pressure source of at least 150 psi. Check for leaks at all assembly joints using a suitable leak detector solution such as “Marshall Excelsior” leak detector.

!CAUTION!

Torque specifications on the POL Tailpiece (50 ft-lbs), Gland (50 ft-lbs), Bonnet (50 ft-lbs), and Body Set Screw (50 in-lbs) must be met to insure a proper and reliable seal.

If any joint or seal continues to leak after reassembly, do not continue to use the valve.

Marshall Excelsior Company

1506 George Brown Drive Marshall, MI 49068
Phone (269) 789-6700 Fax (269) 781-8340
www.marshallexcelsior.com

The contents of this publication are for informational purposes only. While every effort has been made to ensure accuracy, these contents are not to be construed as warranties or guarantees, expressed or implied, regarding the products or services described herein or for their use or applicability. Marshall Excelsior Co. reserves the right to modify or improve the designs or specifications of such products at any time without notice. The MEC™ logo is the trademark of Marshall Excelsior Co.

ME779-VRK

Item Number	Description	Qty.	Included in Repair kit
1	Body	1	No
2	Body Seal	1	Yes
3	Body Set Screw	1	Yes
4	POL Tailpiece	1	Yes
5	Collet Washer	1	Yes
6	Split Nut	1	Yes
6a	#1 (One Dot)	1	Yes
6b	#2 (Two Dots)	1	Yes
6c	#3 (Three Dots)	1	Yes
6d	#4 (Four Dots)	1	Yes
7	Conical Bearing	1	Yes
8	Spring, Light	1	Yes
9	Collar	1	Yes
10	Spring	1	Yes
11	Spacer	1	Yes
12	Stem assembly	1	Yes
12a	Gland	1	Yes
12b	Inner O-ring	1	Yes
12c	Outer O-ring	1	Yes
12d	Stem	1	Yes
12e	Seal Retainer	1	Yes
12f	Stem Seal	1	Yes
12g	Stem Guide	1	Yes
12h	Locking Set Screw	1	Yes
13	Upper Stem	1	Yes
14	Upper Stem Retainer	1	Yes
15	Closing Spring Retainer	1	Yes
16	Closing Spring	1	Yes
17	Bonnet	1	Yes
18	Handle	1	Yes
19	Handle Latch	1	Yes
20	Handle Latch Spring	1	Yes
21	Dowel Pin	2	Yes
22	Elbow	1	No

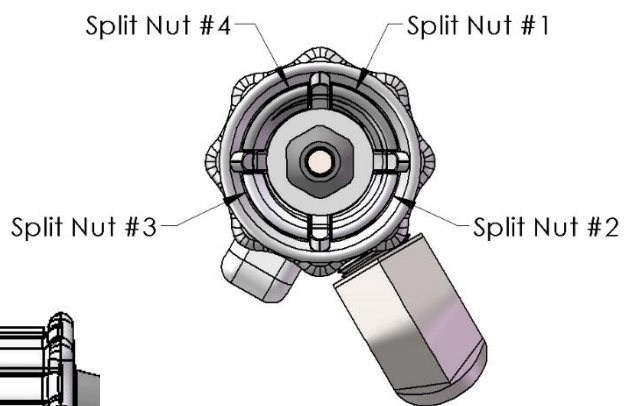
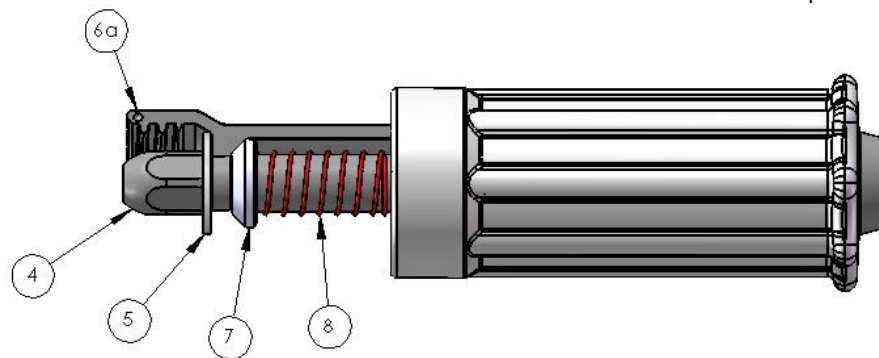

ME779-VRK

